



BREATHE EASY...Solutions for Clean, Safe Air

MC1500

Specifications and Technical Data

TYPICAL APPLICATIONS:

SOURCE CAPTURE OF:

- HEAVY PRODUCTION WELD SMOKE/FUMES
- GRINDING DUST
- SOLVENT ODOR CONTROL
- OTHER DUSTS / FUMES / MISTS
- ODOR CONTROL

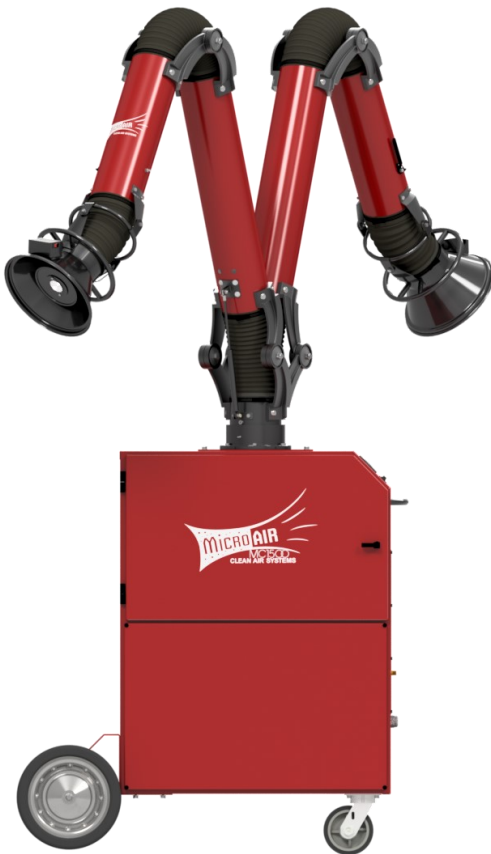

DUAL ARM MC1500 WITH BIG WHEEL KIT

STANDARD FEATURES:

- REVOLUTIONARY ROTO-PULSE FILTER CLEANING SYSTEM
- EXTERNALLY SUPPORTED ARMS
- DUAL ARM CAPABILITY
- VORTEX AIR FLOW PATTERN
- QUIET OPERATION
- HOOD MOUNTED CONTROLS
- LIGHTED SWIVEL HOOD FOR IMPROVED VISIBILITY
- POSITIVE SEALING CABINET AND DOOR

OPTIONS:

- AUTOMATIC AFTER-PULSE FILTER CLEANING
- OPTIONAL HEPA AND / OR CARBON AFTER-FILTERS
- BIG WHEEL KIT
- SINGLE 8" DIA ARM
- DUAL ARMS (6" DIA ARMS ONLY)
- 7' LENGTH OR 9' LENGTH ARM OPTIONS
- VARIETY OF CARTRIDGE FILTER OPTIONS

ROTO-PULSE CLEANING SYSTEM... HOW IT WORKS:

Air is pulsed into a specially designed stainless steel rotating tube with pre-drilled holes.

As the air enters this tube, the force of the pulse causes the tube to rotate. While rotating, air exits the pre-drilled holes.

The result is that air hits **the entire inside of the cartridge**, pulsing dirt particles away from the filter for a more efficient cleaning cycle.

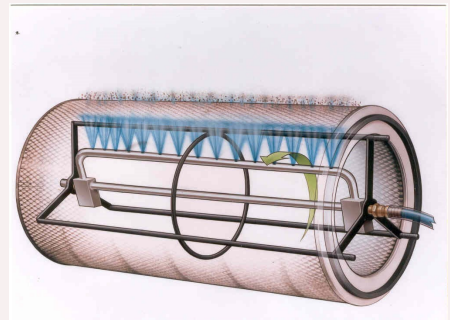

Sold and Serviced by:



MC1500

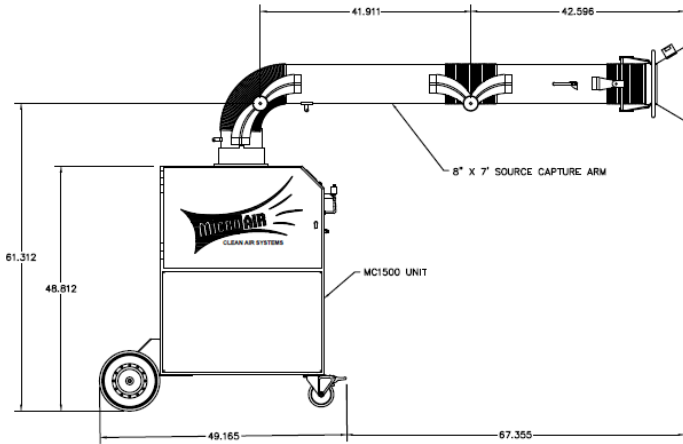

MC1500 Equipped With Single 8" Dia X 7'L Source Capture Arm

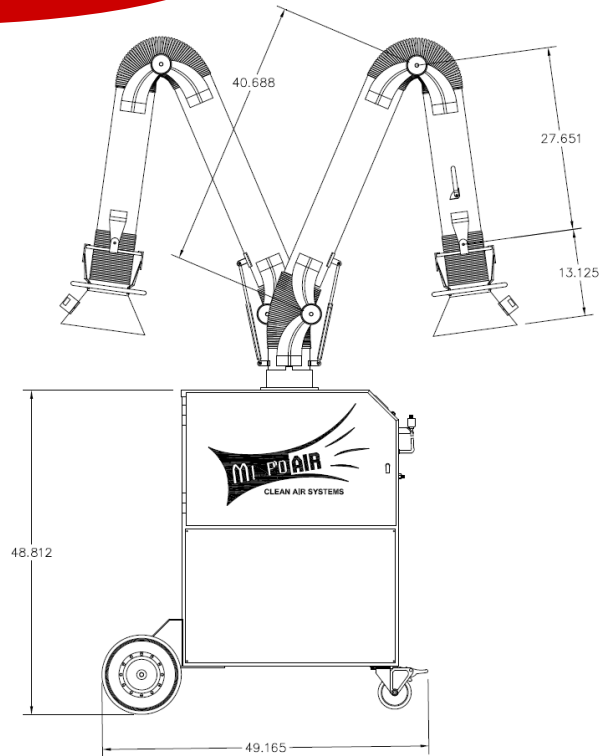

MC1500 EQUIPPED WITH 2 EA. 6" DIA X 7' L SOURCE CAPTURE ARMS

MC1500 SPECIFICATIONS:

OVERALL DIMENSIONS:

48" H X 36.5" W X 35" D

WEIGHT:

- *475 LBS ACTUAL WEIGHT
- *515 LBS SHIPPING WEIGHT
- *WEIGHT VARIES DEPENDING UPON OPTIONS SELECTED

CABINET:

HEAVY DUTY 16 GA. WELDED GALVANEAL STEEL W/EXTERIOR SURFACES GROUND SMOOTH

FINISH:

INDUSTRIAL GRADE TEXTURED BAKED
CRIMSON RED ENAMEL PAINT—INSIDE AND OUT

FILTRATION:

(2) EACH HIGH EFFICIENCY, FIRE RETARDANT 80/20 CARTRIDGES
174 SF MEDIA EA., 348 SF MEDIA TOTAL

FILTER ACCESS:

SIDE LOAD THROUGH HINGED DOOR FOR EASY ACCESS

ARM OPTIONS:

- 6" AND 8" DIAMETER,
- 7' OR 9' LENGTHS,
- DUAL ARM CAPABILITY WITH 6" DIA ARMS,
- 355 DEGREE ROTATION AT BASE

NOISE LEVEL:

- 90 dBA @ 6" FROM EXHAUST—NO SILENCER
- 85 DBA @ 6' FROM EXHAUST WITH SILENCER

INLET / EXHAUST:

INLET AT HOOD OF SOURCE CAPTURE ARM / EXHAUST OUT BOTTOM OF UNIT

AIR VOLUME:

1,500 CFM NOMINAL, DEPENDING ON OPTIONS SELECTED.

MOTOR OPTIONS:

SINGLE SPEED, 5 HP, 3 PH., 208-230/460V, 60 HZ, TEFC MOTOR

BLOWER:

14" DIAMETER BACKWARD INCLIND IMPELLER WHEEL

ELECTRICAL:

5 HP—230/460V, 60 HZ, 3 PHASE, ELECTRICAL PLUG INCLUDED WITH 10' POWER CORD. CONTROL CORD FOR HOOD LIGHT MOUNTS FLUSH TO TOP OF CABINET. UNIT ON/OFF SWITCHES OPERTE AT 12/24 VAC FOR OPERATOR SAFETY

MAX CURRENT

5 HP 230/460V—13.0 / 6.5 AMP

CONTROLS:

HOOD MOUNTED, SWITCHES FOR MOTOR/BLOWER AND LIGHT. CARTRIDGE BACKFLUSH TOGGLE VALVE MOUNTED ON FRONT OF CABINET FOR EASY ACCESS AND PROTECTION FROM BREAKAGE.

AIR VOLUME:

800—1600 CRM, DEPENDENT ON OPTIONS SELECTED. CONSULT FACTORY

CARTRIDGE CLEANING SYSTEM:

ROTO-PULSE® UNIQUE ROTATING TUVE WITH PRE-DRILLED HOLES. AS AIR IS PULSED INTO THE TUBE, IT ROTATES AND AIR EXITS THE PRE-DRILLED HOLES, PROVIDING A HIGHLY EFFICIENT CLEANING OF THE CARTRIDGE FILTERS

CASTORS:

HEAVY DUTY CASTERS, TWO SWIVEL AND TWO FIXED

SPECIFICATIONS SUBJECT TO CHANGE WITHOUT NOTICE