

MC3000

Specifications and Technical Data

TYPICAL APPLICATIONS

- Grinding Dust
- Sanding / Polishing Dust
- Welding Smoke & Fumes
- Powders
- Other Dry Dusts

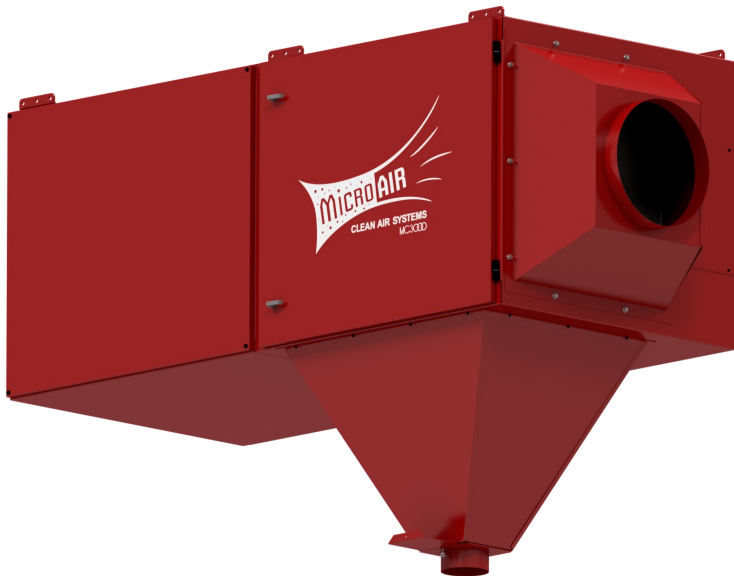

STANDARD FEATURES:

- Revolutionary Roto-Pulse Filter Cleaning System
- High Capacity Allows for Multiple Drops without a Loss in CFM
- Modular Design
- Built-In Silencer Plenum
- Hinged Door for Easy Filter Access
- Motor Starter/Overload Relay Standard
- After Pulse Cleaning Standard
- 2" Mesh Pre-Filter
- Magnahelic Gauge

OPTIONS:

- Hopper with Blast Gate or Dust Tray
- Optional Inlet Plenum
- Optional After-Filter Module with HEPA or Carbon Modules—Available with or without Magnahelic Gauge
- Optional Side Exhaust Plenum
- Variety of Cartridge Filter Options
- Remote on/Off Switch Kit (NEMA-1)
- 7.5 HP Motor

HOW IT WORKS:

Roto-Pulse® Cartridge cleaning system provides for 30-40% better cleaning of the cartridges. Air is pulsed into a specially designed aluminum rotating tube equipped with pre-drilled holes. As the air enters this tube, the force of the pulse causes the tube to rotate. As the tube spins, air exits the pre-drilled holes resulting in air hitting the entire inside length of the cartridge, pulsing dirt particles away from the filter for a much more efficient cleaning cycle and increased filter life.

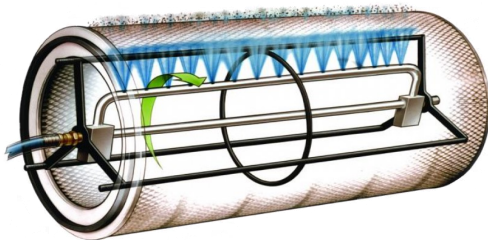

L22242-02/2022



MC3000

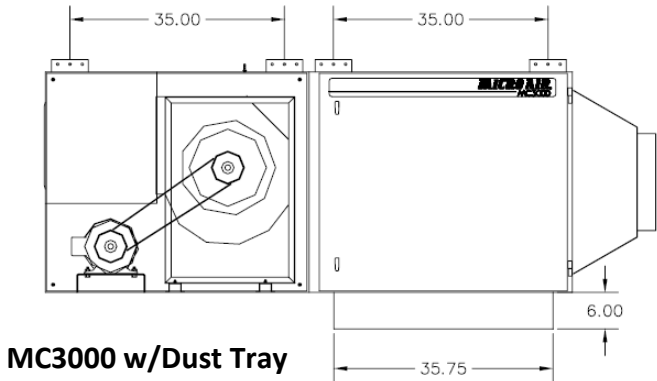
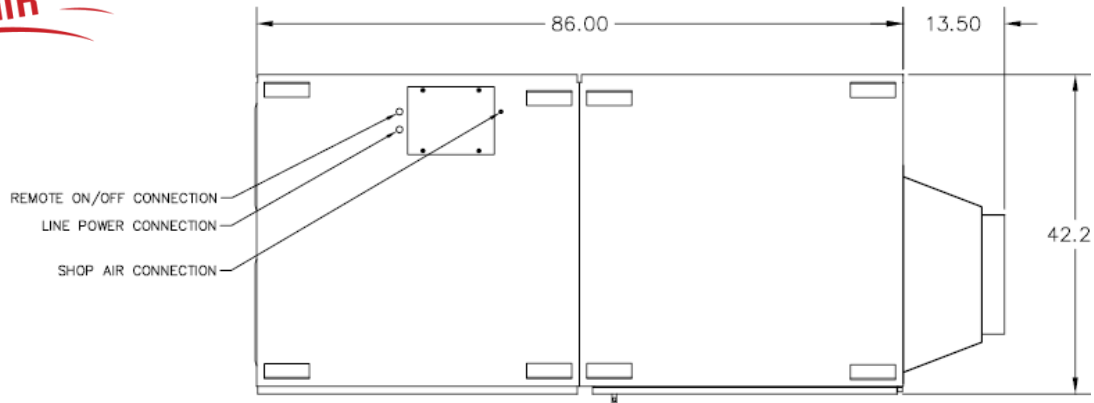

MC3000 w/Dust Tray

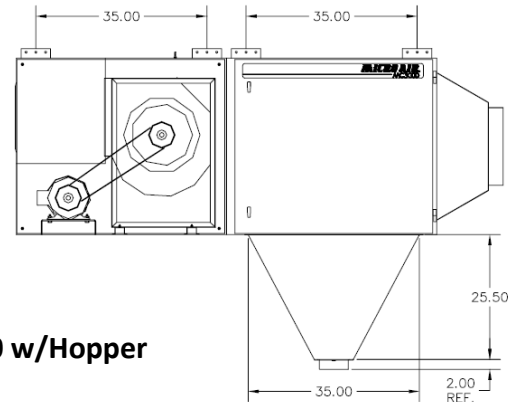

MC3000 w/Hopper

MC3000SPECIFICATIONS:

OVERALL DIMENSIONS:

36" H X 42" W X 86" L
 36"H X 42" W X 99.5" L w/ Inlet Plenum

WEIGHT:

950 LBS - ACTUAL-VARIES DEPENDING ON
 OPTIONS SELECTED

CABINET:

14 GA. WELDED GALVANEAL STEEL W/EXTERIOR
 SURFACES GROUND SMOOTH

FINISH:

INDUSTRIAL GRADE TEXTURED BAKED
 CRIMSON RED ENAMEL PAINT—INSIDE AND OUT

FILTRATION:

2" MESH PREFILTER
 FOUR EA. FIRE-RETARDANT CARTRIDGE,
 200-348 SF MEDIA—DEPENDENT ON MEDIA
 SELECTED—MERV 11—16 AVAILABLE

ROTO-PULSE® CLEANING SYSTEM:

REVOLUTIONARY CLEANING SYSTEM, THAT
 CLEANS THE ENTIRE SURFACE OF CARTRIDGE,
 FOR CLEANER FILTERS & EXTENDED FILTER
 LIFE

FILTER ACCESS:

SIDE LOAD THROUGH HINGED DOOR FOR
 EASE OF ACCESS

AIR VOLUME:

3,000 CFM NOMINAL—CONSULT BLOWER CURVES
 FOR SPECIFIC CONFIGURATIONS

FILTER CHANGE INDICATOR:

MAGNAHELIC GAUGE

EXHAUST:

STRAIGHT THROUGH / SIDE EXHAUST OPTIONAL

MOTOR:

5 HP, 230 / 460V, 3 PHASE, TEFC
 7.5 HP, 230 / 460v, 3 PHASE, TEFC

MAX CURRENT:

5 HP—13.6 / 6.8 AMP
 7.5 HP—19.6 / 9.9 AMP

BLOWER:

BELT DRIVEN, FORWARD INCLINED BLOWER

FILTER CHANGE INDICATOR:

0-5" MINIHELIC GAUGE

ELECTRICAL:

230 /460V, 3 PHASE— INCLUDES
 FACTORY WIRED ON/OFF SWITCH, LIGHT
 SWITCH, & PULSE PUSH BUTTON

NOISE LEVEL:

76 DbA @ 6" FROM EXHAUST

CONTROLS:

ON/OFF SWITCH WITH STARTER AND
 OVERLOAD RELAY

SPECIFICATIONS SUBJECT TO CHANGE WITHOUT NOTICE

L2242-02/2022