



BREATHE EASY...Solutions for Clean, Safe Air

MICRO AIR TM500 Specifications and Technical Data

TYPICAL APPLICATIONS: Source Capture of:

- WELD SMOKE AND FUMES
- GRINDING DUST
- PARTICULATE FROM BUFFING/POLISHING
- DRY PARTICULATE



STANDARD FEATURES:

- COMPACT DESIGN PROVIDES FOR EASE OF MOVEMENT
- SMALL FOOTPRINT SAVES VALUABLE FLOOR SPACE
- INTEGRATED SPARK TRAP
- BAFFLE IMPINGER
- INDUSTRIAL GRADE SWIVEL CASTERS
- ALL METAL CONSTRUCTION
- EASY PLUG & PLAY INSTALLATION / OPERATION
- LOW POWER REQUIREMENTS
- 120 V, SINGLE PHASE, 10 FLA
- CHOICE OF ATTACHMENTS TO ADAPT TO MULTIPLE APPLICATIONS OR PROCESSES
- DISPOSABLE FILTER

OPTIONS:

- 4" DIA. X 5' SOURCE CAPTURE ARM
- 6" DIA. X 7' FLEX HOSE WITH MAGNETIC HOOD
- 6" DIA X 5' SOURCE CAPTURE ARM—WALL MOUNT OPTION
- 95% DOP HEPA MAIN FILTER
- 99.97% DOP HEPA FILTER

HOW IT WORKS:

Contaminated Air is pulled into the hood on the source capture arm or flex hose attachment, then, travels down through the pre-filter and filter sections, where the contaminant is filtered and captured. Clean, safe air is exhausted out the back side of the unit.



TM500 FILTER SECTION



TM500 FLEX HOSE W/ HOOD

Specifications subject to change without notice.

L2868—TM500-04/22



TM500

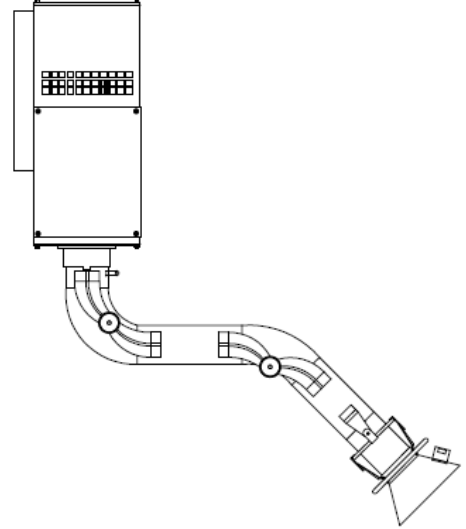
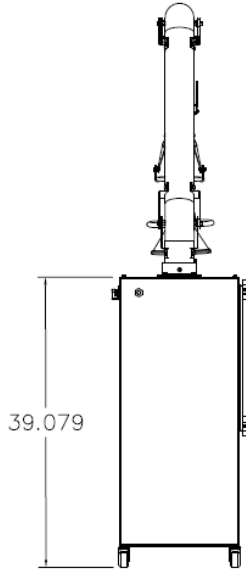
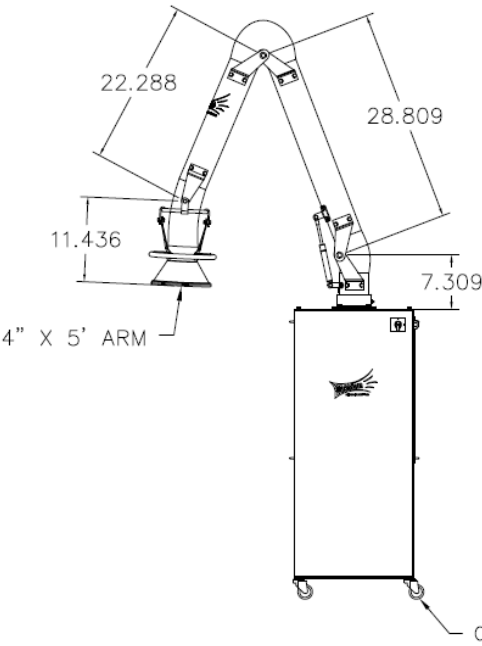
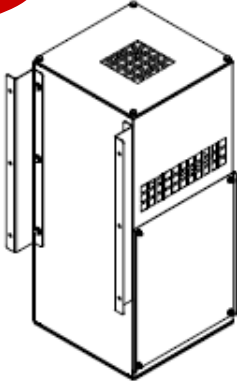
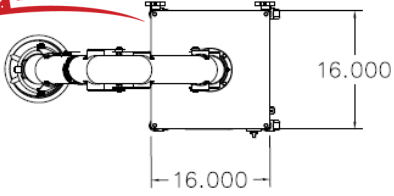

TM500 Portable with 4" X 5' Arm

TM500—Wall Mount

TM500 SPECIFICATIONS:

OVERALL DIMENSIONS:

BASE UNIT: 16" W X 16" D X 39" H W/ CASTERS
 BASE UNIT W/ARM: 16" W X 16" D X 78" H W/ CASTERS

BASE WEIGHT:

*148 LBS ACTUAL WEIGHT
 *175 LBS SHIPPING WEIGHT
 *WEIGHT VARIES DEPENDING UPON OPTIONS SELECTED

CABINET:

HEAVY DUTY 14 GA. WELDED GALFANEAL STEEL W/EXTERIOR SURFACES GROUND SMOOTH

FINISH:

INDUSTRIAL GRADE TEXTURED BAKED CRIMSON RED ENAMEL PAINT IN SIDE AND OUT

FILTER ACCESS:

REAR LOAD FOR EASY ACCESS

MOTOR:

3/4 HP, 120V, 60 Hz, SINGLE PHASE, TEFC MOTOR

BLOWER:

HIGH PRESSURE DIRECT DRIVE BLOWER, 3450 RPM

AIR VOLUME:

700 CFM - 6+" FLEX HOSE / 95% DOP HEPA
 600 CFM—6" FLEX HOSE / 99.97% DOP HEPA
 450 CFM—4" X 5' ARM / 95% DOP HEPA
 400 CFM—4" X 5' ARM / 99.97% DOP HEPA

FILTRATION:

DISPOSABLE FILTERS—95% DOP HEPA—MERV 16 OR 99.97% DOP HEPA— MERV 17

CASTERS:

INDUSTRIAL GRADE—TWO SWIVEL AND TWO FIXED FOR EASE OF MOQBILITY

CONTROLS:

FRONT, CABINET MOUNTED ON / OFF SWITCH

INLET / EXHAUST:

INLET—HOOD ON SOURCE CAPTURE ARM
 EXHAUST - OUT REAR OF UNIT

MAX CURRENT

120V—10 FLA

NOISE LEVELS:

70.3 dBA @ 6' AVERAGE WITH 99.97% DOP HEPA
 76 dBA @ 6' AVERAGE WITH 95% DOP HEPA

OPTIONAL ATTACHMENTS:

4" DIA X 5' L SOURCE CAPTURE ARM—PORTABLE OPTION
 6" DIA. X 7' L FLEX HOSE WITH MAGNETIC HOOD
 6" DIA. X 5' L SOURCE CAPTURE ARM—WALL MOUNT OPTION

ATTACHMENT CONNECTION:

PLATE W/4" DIA. SWIVEL BASE FOR 4" X 5' ARM
 PLATE WITH 6" DIA. COLLAR FOR FLEX HOSE / MAGNETIC HOOD

SPECIFICATIONS SUBJECT TO CHANGE WITHOUT NOTICE