

MICRO AIR **AIR CLEANERS**



Model MT800

OWNER'S MANUAL

CAUTION

READ COMPLETE INSTRUCTIONS BEFORE OPERATING.
PLEASE FILE FOR FUTURE REFERENCE.

PRE-OPERATING INSTRUCTIONS

1. Unpack the unit from the carton and remove any plastic wrap from around the unit.
2. Inspect the unit for any freight damage. Report any damage to the freight company.
3. Remove the foam prefilter from the unit. Behind this filter is the media bag filter. Remove this filter and cut the band that is holding the pockets in place. Behind the bag filter is the charcoal filter. Remove this filter and take off the plastic wrap.
4. Put the charcoal filter back in the unit, followed by the bag filter and , finally, the prefilter. Be sure not to tear the delicate media of the bag filter when installing it in the unit.

INSTALLATION INSTRUCTIONS

The MT800 can be hung from the ceiling or mounted on wall brackets. When hanging the MT800, please note the following steps:

1. Remove the four plastic plugs from the corners located on the top or bottom of the unit.

NOTE: The MT800 is designed to work equally well whether hung from the top or bottom.

2. Install an eyebolt into each hole. The unit is now ready to be hung in an appropriate location.

CAUTION: USE STRONG WIRE OR CHAIN TO SUPPORT THE AIR CLEANER. HANG FROM STRUCTURAL SUPPORTS.

NOTE: If a unit is to be installed on brackets against a wall, use brackets strong enough to hold the unit. Install brackets securely into the wall.

OPERATING INSTRUCTIONS:

1. Plug the power cord into a 115 volt, 60 Hz outlet.
2. Flip the toggle switch up or down to turn unit on. Speed control is either low or high to allow for the proper air flow for the particular situation.

FILTER REPLACEMENT

1. The foam prefilter can be washed. Wash the prefilter in a mild detergent. Rinse thoroughly and press excess water from the filter, using a towel or cloth.
2. To install a new bag filter or a charcoal filter, turn the unit off. Remove the filter and insert a new filter.

NOTE: Be careful not to tear the media of the bag filter when installing a new filter.

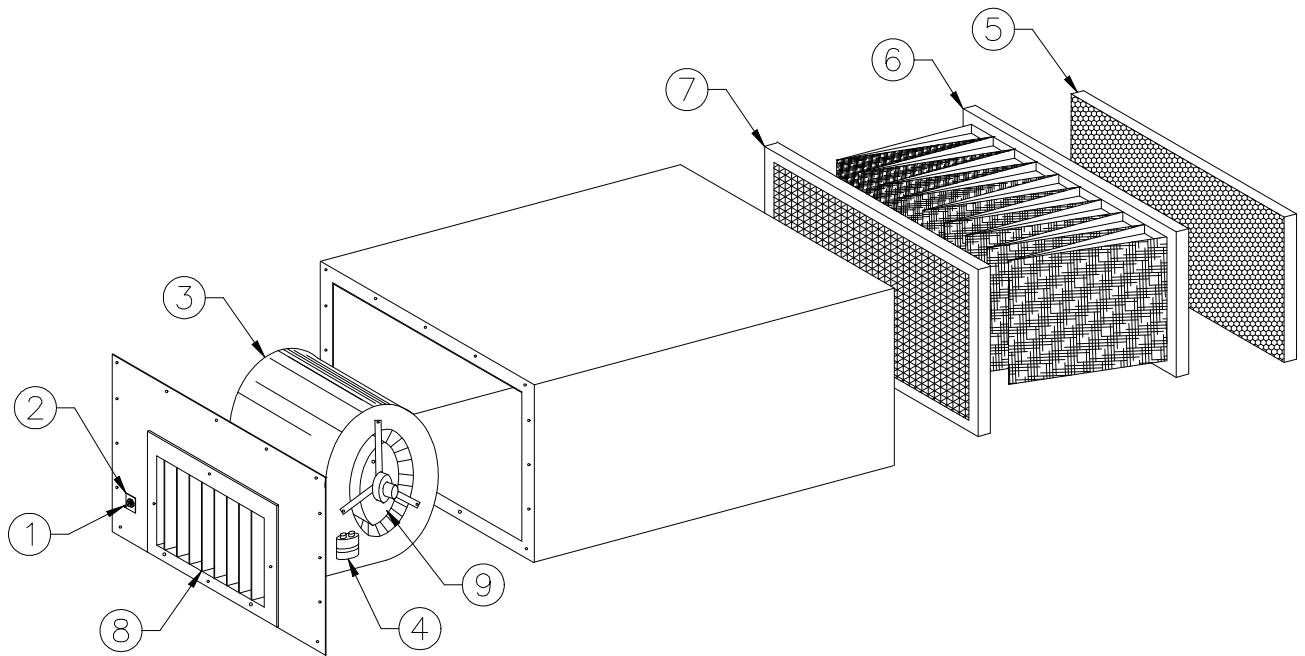

No.	Part Number	Description	Qty.
1.	P1354	TOGGLE SWITCH	1
Not Shown	P1363	CORD SET - 10'	1
2.	P1394	SWITCH PLATE	1
3.	P1432	BLOWER	1
4.	P1469	MOTOR CAPACITOR	1
5.	P1613	PRE-FILTER	1
6.	P1615	BAG FILTER	1
7.	P1619	CHARCOAL FILTER	1
8.	P1704	GRILLE	1
Not Shown	P2626	RESISTOR	1
Not Shown	P2627	RESISTOR BRACKET	2
9.	P2969	MOTOR	1

MICRO AIR[®]
AIR CLEANERS

Products of Metal-Fab, Inc.
P.O. Box 1138 • Wichita, KS. 67201
(316) 943 2351 • FAX (316)943-2717