

MICROAIR[®]

AIR CLEANERS

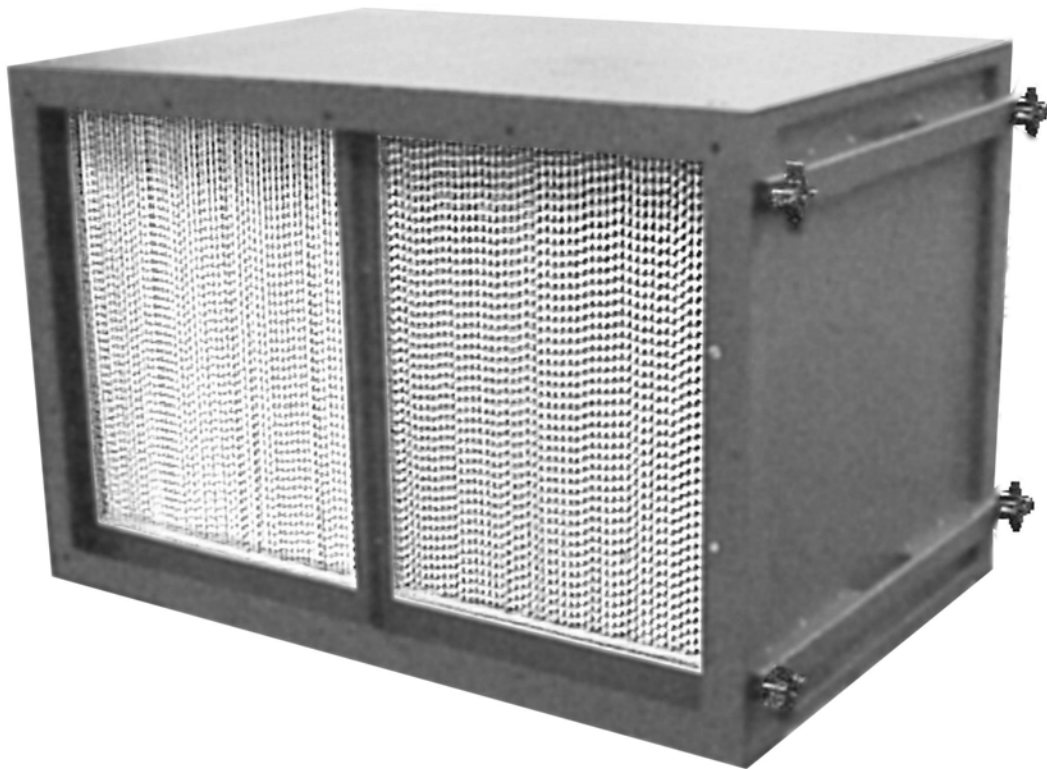

MODEL SF4000

OWNER'S MANUAL

CAUTION

**Read complete instructions before operating.
Please file for future reference.**

MODEL SF4000 SPECIFICATIONS

Overall Dimensions: 27"H x 42"W x 22"L

Weight: 115 lbs. without filters

175 lbs. with HEPA filters

Cabinet: 16 gauge welded galvanized steel with exterior surfaces ground smooth

Finish: Industrial grade crimson red textured baked enamel, inside and outside.

Filtration: Two each 95% HEPA filters, or

Two each 99.9% HEPA filters,

Filter Access: Side load.

Air Flow: Horizontal from right to left, or left to right.

Air Volume Capacity: 4000 CFM.

Specifications subject to change without notice.

FEATURES

Units can be easily stacked or mounted side by side or top to bottom for greater capacity.

Sealed cabinet for positive pressure environment.

PACKAGE CONTENTS

1 ea. SF4000 Unit

1 ea. Owners Manual

4 ea. 5/16 x 18" Eye Bolt

8 ea. 5/16 x 18" Hex Nut

8 ea. Flat Washer

4 ea. Lock Washers

PRE-OPERATING INSTRUCTIONS

1. Remove the SF4000 from carton and inspect for any external damage. Remove plastic packaging from unit.
2. Open the filter access door and inspect the HEPA modules for any damage.
3. Verify filters are securely placed in cabinet.

HANGING INSTRUCTIONS

1. The SF4000 cabinet contains eight securing holes located on top and bottom corners to be used with eyebolts or threaded rods for suspended installation. The recommended style of attachment is shown in **FIG. 1**, and described in Steps 3 through 5.
2. To install hanging hardware, simply remove plastic hole plugs and discard.

NOTE: The SF4000 is designed to work equally well whether hung from top or bottom.

3. Thread a nut approximately 1" onto the eyebolt and insert the eyebolt into the appropriate hole in the top of the cabinet. Place the flat washer and lock washer on the threaded portion of the eyebolt, thread one nut on to the end of the eye bolt. Repeat for the other three holes. The unit is now ready to hang in the appropriate location.

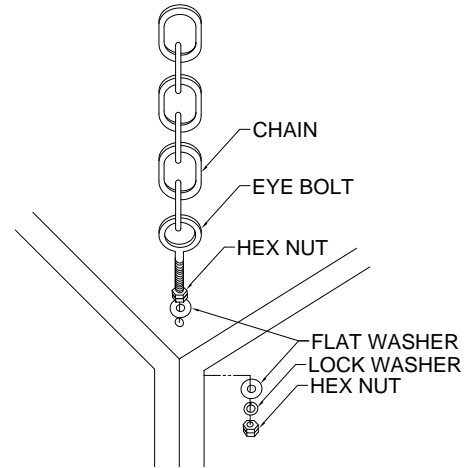

FIG. 1

4. Firmly secure four chains of equal length to a firm structural support. Wire of equal or greater strength may be used in lieu of chains (**FIG. 1**).
5. Raise unit up to chains and attach eyebolts to chains.

CAUTION: FIRM STRUCTURE MUST BE CAPABLE OF SUPPORTING A MINIMUM WEIGHT OF 700 LBS. PER SF4000 USED.

Flanges on intake and exhaust side of unit are provided for attaching to ducting.

CAUTION: TAKE CARE TO USE APPROPRIATE SCREW LENGTH WHEN ATTACHING PLENUMS SO THAT SCREWS DO NOT INTERFERE WITH INTERNAL COMPONENTS OF UNIT.

NOTE: Locate unit such that serviceable parts can be removed without interference from structural poles or walls.

CAUTION: IF UNIT IS TO BE SUSPENDED BY OTHER MEANS, SUCH AS AN ANGLE IRON ASSEMBLY OR A WALL MOUNT, BE CERTAIN THAT SUCH AN ASSEMBLY CAN SUPPORT FOUR TIMES THE TOTAL WEIGHT OF THE UNIT(S) INSTALLED.

ATTACHING THE SF4000 TO OTHER UNITS

1. The SF4000 contains numerous 5/16" holes located on the inlet and exhaust flanges. These holes are to be used to attach the SF4000 to plenums or another SF4000.
2. By using the 5/16" flange holes of the SF4000, locate and drill adjacent holes on the ducting to which the SF4000 will be attached. (1/4" diameter holes minimum are recommended.)
3. Before attaching the SF4000 to any structures, apply a thick bead of silicon sealant around flange surface so that an air tight seal is generated. Once done, the SF4000 should be bonded to the structure with a minimum of eight (2 per flange) 1/4" bolts, nuts and washers (not provided).

The following resistance curves are provided for properly sizing the SF4000 to air flow system design.

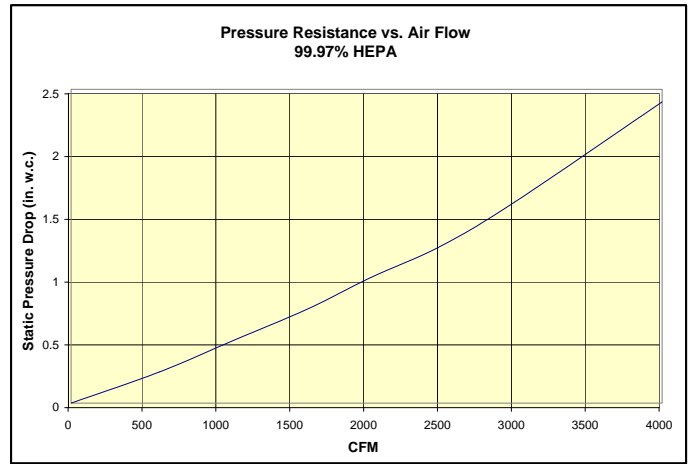
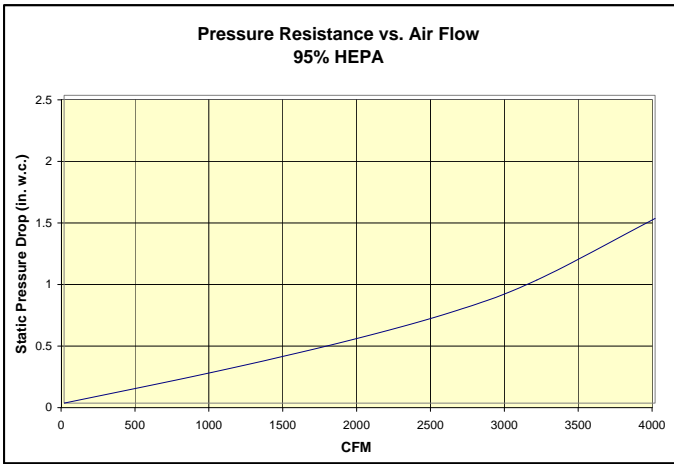

MICROAIR®
AIR CLEANERS

SF4000

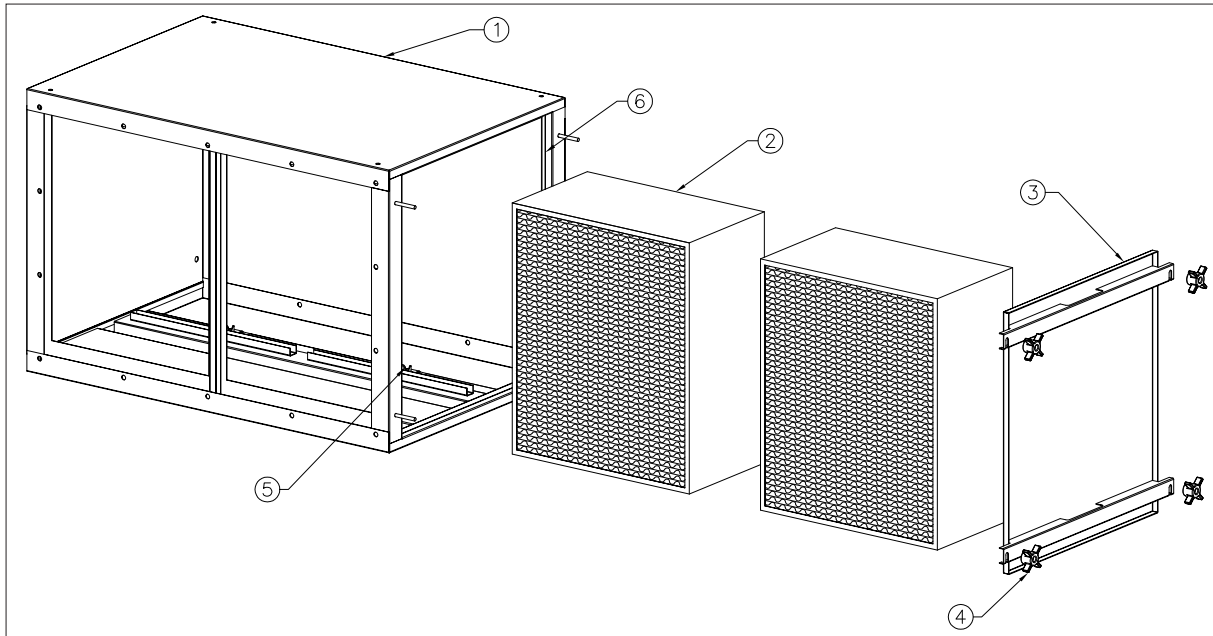

- | | | |
|----|----------|---------------------------------|
| 1. | 38461-01 | Cabinet Weldment |
| 2. | P3275 | 95% HEPA |
| | P3276 | 99.97% HEPA |
| 3. | 38469-01 | Door Weldment |
| 4. | P3649 | Four Prong Knobs |
| 5. | 38475-01 | Filter Lock Assembly |
| 6. | P1887 | Door Seal Gasket (6.5 ft Total) |

MICROAIR®
AIR CLEANERS

Products of Metal-Fab, Inc.

P.O. Box 1138 • Wichita, KS 67201
(316) 943-2351 • FAX (316) 943-2717

Litho in U.S.A.

©2001 Metal-Fab, Inc. Form No. L1875 04/01
6386