

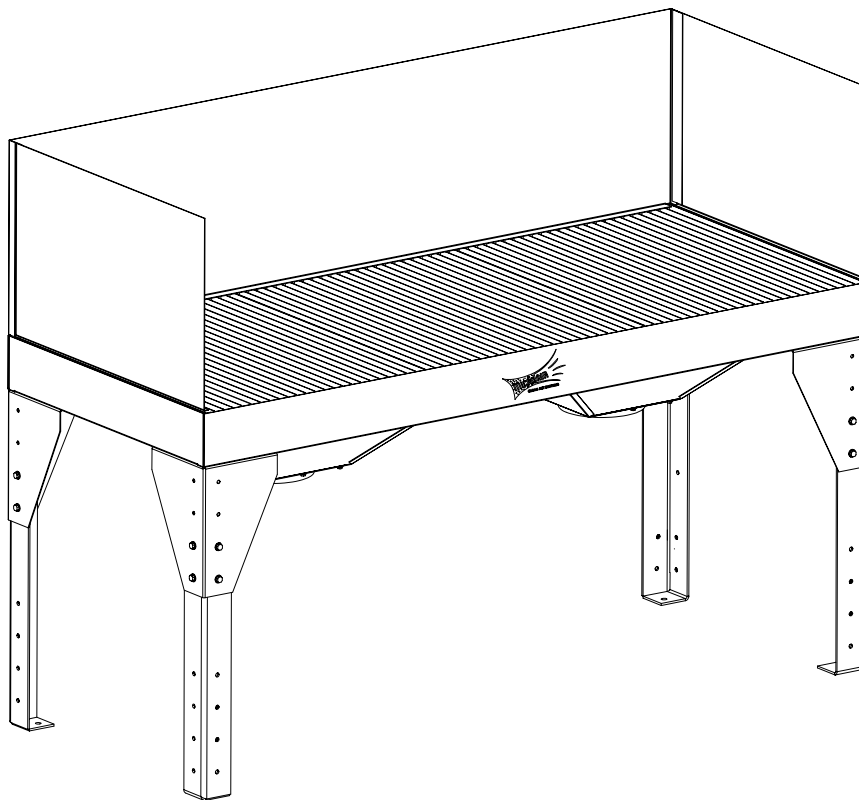

**MICRO-AIR DOWNDRAFT TABLES
INSTALLATION AND OPERATION MANUAL
DDT4830 & DDT7230**

Includes Installation, Operation, and Service Instructions



IMPORTANT

This manual contains specific cautionary statements relative to worker safety. Read this manual thoroughly and follow as directed. It is impossible to list all of the hazards of dust control equipment. It is important that use of the equipment be discussed with a Micro-Air® Representative. Persons involved with the equipment or systems should be instructed to operate in a safe manner.



CAUTION

- Avoid mixing combustible materials, such as buffing lint, paper, wood, aluminum, and magnesium dust, and with dust generated from grinding ferrous metals due to the potential fire hazard caused by sparks in the dust collector.
- Under no conditions should the persons operating the dust collector be allowed to put cigarettes or any burning object into the hood or ducting of any dust collector system.
- All users of Micro-Air® Equipment should comply with all National and Local Fire Codes and / or other appropriate codes when determining the location and operation of dust control equipment.

SPECIFICATIONS

CABINET DIMENSIONS AND WEIGHTS

4830 57 3/4" max. H x 48 3/8" W x 30" D 255lbs.
7230 57 3/4" max. H x 72 3/8" W x 30" D 285lbs.

DUST TRAY CAPACITY (OPTIONAL)

432 Cubic inches total

INSTALLATION

INSPECTION

The Micro-Air® Clean Downdraft Table is shipped on multiple skids. All skids should be inspected for any visible damage that may have occurred during shipment.

Additional equipment that maybe shipped separately includes:

- | | |
|----------------|----------------|
| Drop-Out Kits | Dust-Tray Kits |
| Hopper Collars | Wheel Kit |
| Grills | |

EQUIPMENT / TOOLS REQUIRED

Equipment and tools needed for proper installation will include the following:

- | | |
|---------------------|-------------------------|
| Crane or Lift Truck | 1/2" Concrete Drill Bit |
| Wrench | 1/2" Anchors |
| Drill | |

ASSEMBLY OF UNIT

1. Remove packaging from table and legs.

NOTE: Leg assembly can be completed while unit is upside down on skid.

2. Place leg on the inside of leg bracket. Align holes in leg to corresponding holes in leg bracket (See **FIG. 1**). The leg can be installed in three different positions. The shortest position will give an approximate table height of 30", the middle setting 33" and the tallest setting 36".
3. Attach leg with provided hardware. Insert all 4 bolts before tightening the nuts.

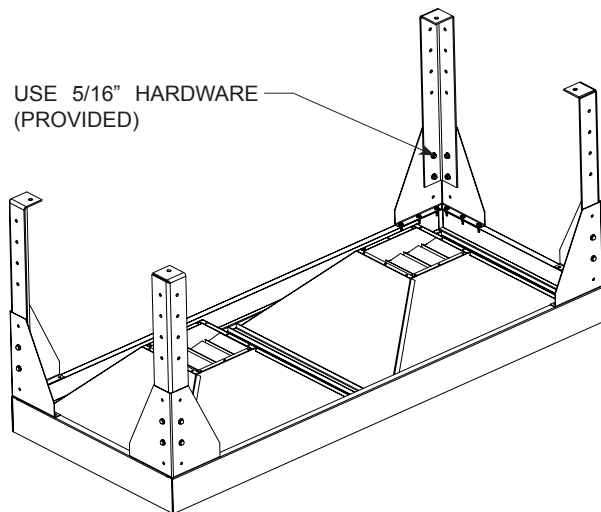

FIG. 1

4. Install optional components prior to turning the unit over. See installation procedure for optional components on pages 3 through 7.
5. Determine location for downdraft table. The table must be located on a hard flat surface capable of holding 1/2" anchor bolts.
6. Move table to location and mark location for anchor bolts. (Unless wheel kit is installed)
7. Move table out of area, drill appropriate holes and place 1/2" anchor bolts.
8. Move/lift table back into position over anchors.
9. Secure table with appropriate nuts/washers.
10. Place appropriate grills on the table.
11. Proceed with installation of optional components.
12. Connect ductwork to collars on the bottom of the hoppers.

Recommended air flow:

Operation	Face Velocity	CFM 48" Table	CFM 72" Table
Heavy Grinding	250-300 FPM	2500 CFM	3750 CFM
Welding	200-250 FPM	2000 CFM	3000 CFM
Fine Dusts	175-200 FPM	1750 CFM	2625 CFM

DDT SHIELD INSTALLATION PROCEDURE

This Kit Includes:

ITEM	PART NO.	DESCRIPTION	QTY	ADDITIONAL INFORMATION
1	37825-01	Shield Assembly	1	DDT4830 Only
	37825-02	Shield Assembly	1	DDT7230 Only
2	P3543	Self Tapping Screw	3	DDT4830 Only
	P3543	Self Drilling/Self Tapping Screw	5	DDT7230 Only

INSTALLATION

1. Remove Shield Assembly from packaging. Inspect for any possible damage incurred during shipment.

NOTE: Grills must be installed prior to installing Shield Assembly.

2. Set Shield Assembly on top of the assembled Downdraft Table. The Screw Plates should overlap at the rear of the table.
3. Center Shield Assembly on table. Verify side shields can move freely.
4. Attach Shield Assembly with provided Self Drilling/Self Tapping Screws.

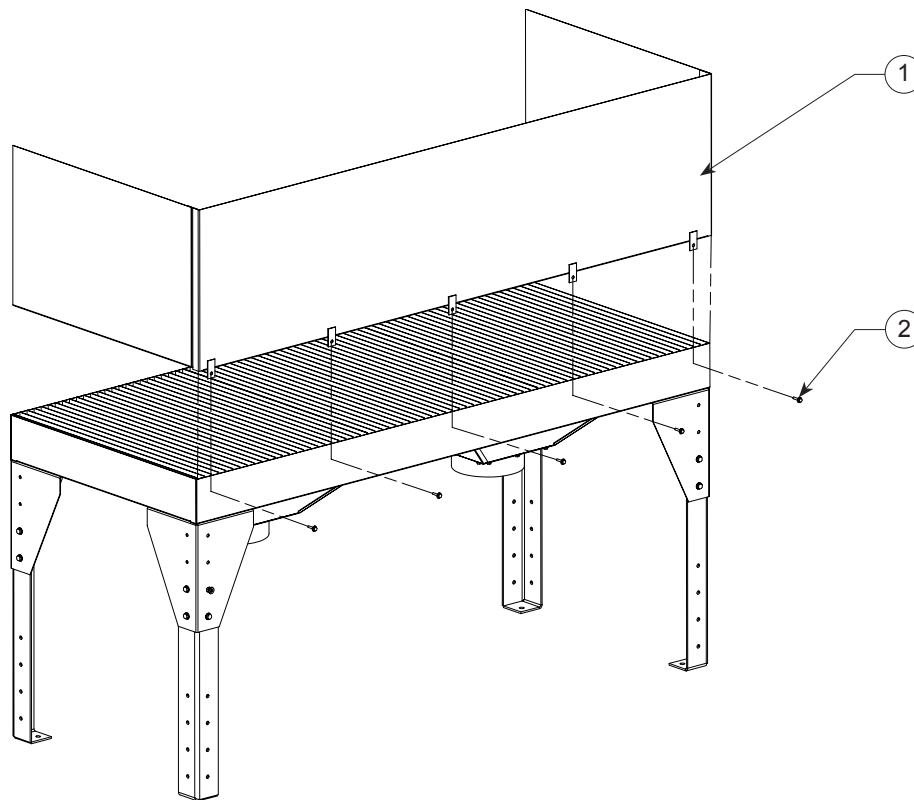

FIG. 2

DDT COLLAR KIT INSTALLATION PROCEDURE

This Kit Includes:

ITEM	PART NO.	DESCRIPTION	QTY
1	37815-01	Hopper Collar	2
2	P3543	Self Drilling/Self Tapping Screw	24
3	P1031	1/4" x 1/2" Foam	80 Inches

INSTALLATION

1. Remove Collar Kit from packaging. Inspect for any possible damage incurred during shipment. If this is a new table, assembly can be done while table is upside down.



CAUTION

Some assembly steps may require lifting and should only be done using proper lifting techniques.

2. Remove backing and place foam on Collar Plate. Foam should cover holes.
3. Line up hole pattern on Collar Plate with hole pattern on Hopper.
4. Screw in twelve screws.
5. Repeat for second hopper.

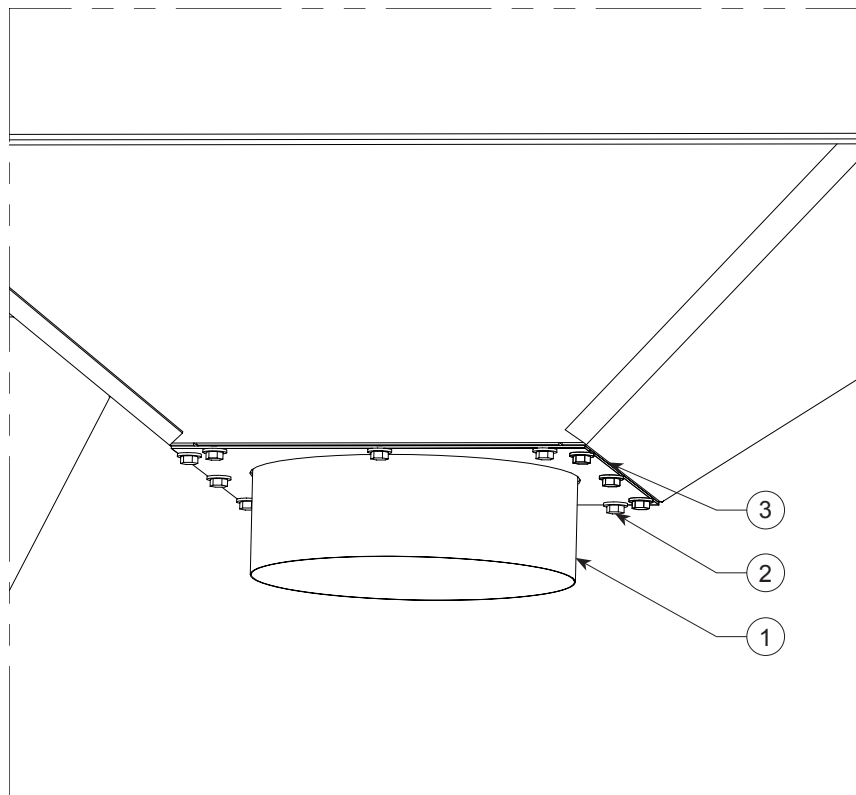

FIG. 3

DDT HOPPER DROP-OUT KIT INSTALLATION PROCEDURE

This Kit Includes:

ITEM	PART NO.	DESCRIPTION	QTY.	ITEM	PART NO.	DESCRIPTION	QTY.
1	37835-01	Hopper Drop-Out (1 Collar)	2	4	P164	1/4-20 Hex Bolt	12
	37835-02	Hopper Drop Out (2 Collars)	Optional		P1729	1/4 Washer	24
2	P3543	Self Drilling/Tapping Screws	24		P203	1/4-20 Nut	12
3	37848-01	Drop Out Blank Plate	2		P242	1/4 Lock Washer	24
	37815-01	Collar	Optional	5	P1031	1/4 x 1/2 Foam	160 Inches

INSTALLATION

1. Remove Hopper Drop-Out kit from packaging. Inspect for any possible damage incurred during shipment. If this is a new table assembly can be done while table is upside-down.



CAUTION

Some assembly steps may require lifting and should only be done using proper lifting techniques.

- Remove backing and place foam on Drop-Out flanges.
- Line up hole pattern on Hopper Drop-Out flanges with hole pattern on Hopper. The Drop-Out Assembly can be rotated to accommodate duct location.
- Screw in twelve screws.

NOTE: Drop-Out Blank Plate can be modified to allow for custom Drop-Out containers.

- Remove backing and place foam on the Blank Drop-Out Plate.
- Line up hole pattern on Drop-Out Blank Plate with hole pattern on flanges of Hopper Drop-Out.
- Attach Drop-Out Blank Plate using provided 1/4" hardware.
- Hopper Collar can be substituted for the Drop-Out Blank Plate (As Shown in **FIG. 4**).
- Repeat for second hopper.

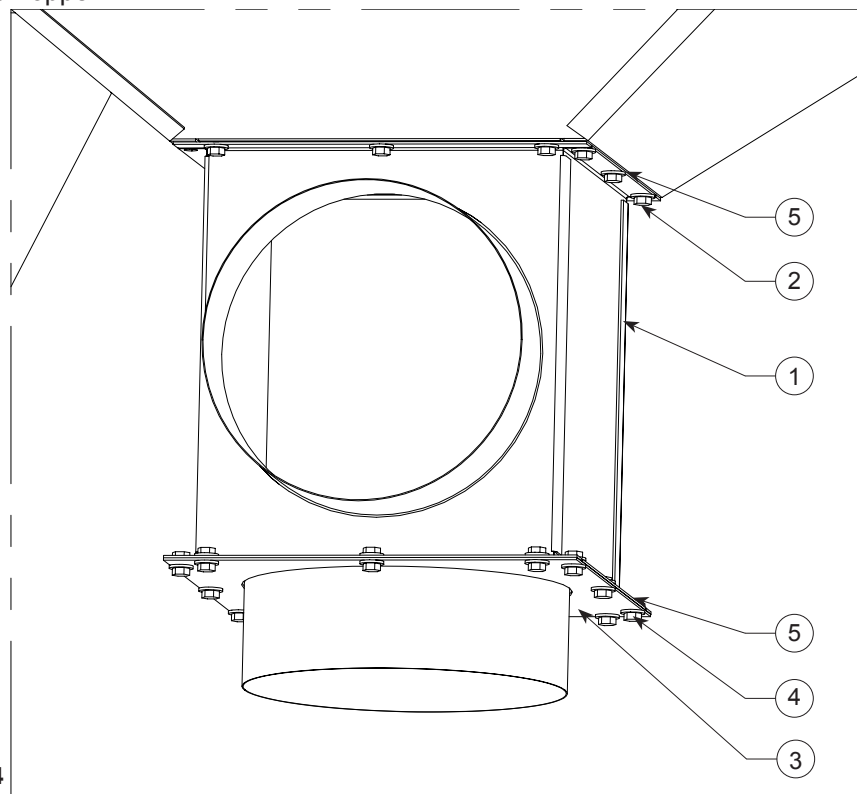

FIG. 4

DDT DUST TRAY KIT INSTALLATION PROCEDURE

This Kit (37840-01) Includes:

ITEM	PART NO.	DESCRIPTION	QTY.
1	37841-01	Dust Tray Wrap	2
2	37842-01	Drawer	2
3	P3506	Knob	2
4	P3686	Foam	60 Inches
5	P164	1/4-20 Hex Bolt	12
	P1729	1/4 Washer	24
	P203	1/4-20 Nut	12
	P242	1/4 Lock Washer	24

INSTALLATION

1. Remove Dust Tray Kit from packaging. Inspect for any possible damage incurred during shipment. If this is a new table assembly can be done while table is upside-down.



Some assembly steps may require lifting and should only be done using proper lifting techniques.

2. Remove backing and place foam on Dust Tray Wrap flanges.
3. Line up hole pattern on Dust Tray Wrap flanges with hole pattern on Drop-Out. The Dust Tray Wrap can be rotated to accommodate drawer removal.
4. Attach Dust Tray Wrap using provided 1/4" hardware.
5. Slide Drawer into Dust Tray Wrap and secure using provided Knobs.
6. Repeat for second hopper.

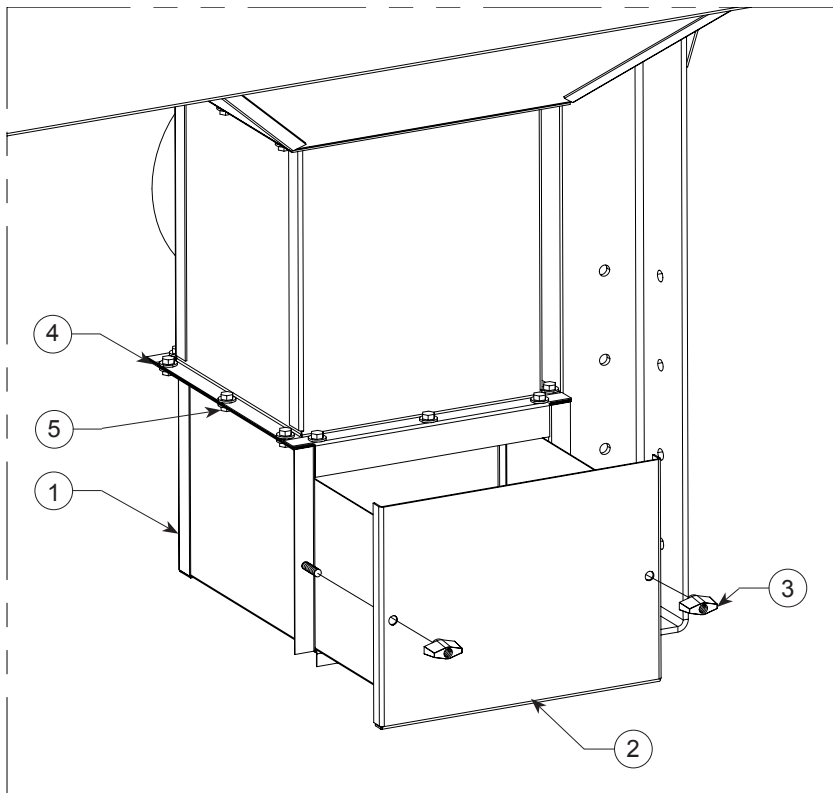

FIG. 5

DDT WHEEL KIT INSTALLATION PROCEDURE

This Kit Includes:

ITEM	PART NO.	DESCRIPTION	QTY.	ADDITIONAL INFORMATION
1	P2334	Swivel Caster Wheel	4	
2	37820-03	30" Leg Brace	2	
3	37820-01	48" Leg Brace	2	(DDT4830 Only)
	37820-03	72" Leg Brace	2	(DDT7230 Only)
4	P164	1/4-20 Hex Bolt	16	
	P1729	1/4 Washer	32	
	P203	1/4-20 Hex Nut	16	
	P242	1/4 Lock Washer	32	
5	P146	1/2-13 Hex Nut	4	
	P147	1/2 Lock Washer	4	
	P3314	1/2 Flat Washer	4	

INSTALLATION

1. Remove wheel kit from packaging. Inspect for any possible damage incurred during shipment. If this is a new table assembly can be done while table is upside-down.



CAUTION

Some Assembly steps require lifting and should only be done using proper lifting techniques.

2. Lift the short end of the table approximately 6" above the floor.
3. Insert threaded shaft of caster through the hole in the bottom of the leg.
4. Repeat for second leg.
5. Place washers and nut on the threaded shaft, Tighten.
6. Lower the end and block so it cannot move.
7. Repeat steps 2 through 6 for the opposite end.
8. Using the provided 1/4" hardware attach the leg braces (See Figure 6). The braces may be lowered or raised to accommodate ductwork.
9. Remove blocks used to hold table.

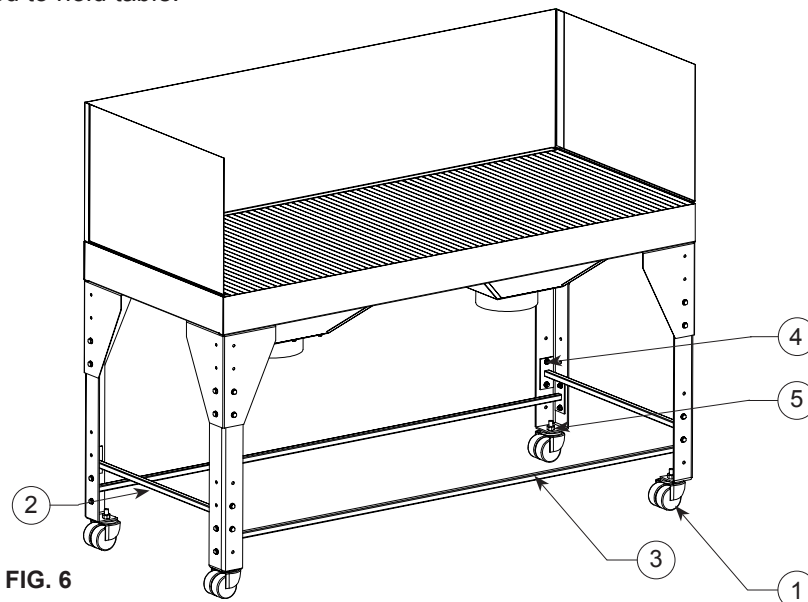

FIG. 6

DDT PARTS LIST

ITEM	PART NO.	DESCRIPTION	ITEM	PART NO.	DESCRIPTION
1.	37800-01	48" x 30" Downdraft Table		37840-01	Drawer/Wrap Assembly (Drawer, Knob, & Wrap)
	37800-02	72" x 30" Downdraft Table	7.	37842-01	Dust Tray Drawer
2.	37825-01	48" Back/Side Shield	8.	P3506	Knob
	37825-02	72" Back/Side Shield	9.	37841-01	Dust Tray Wrap
3.	P2334	Swivel Caster Wheels	10.	37835-01	Hopper Drop-Out One Collar
4.	37820-01	30" Leg Brace		37835-02	Hopper Drop-Out Two Collars
5.	37820-02	48" Leg Brace	11.	37807-01	Black Painted Grill
	37820-03	72" Leg Brace		37808-01	Rubberized Grill
6.	37815-01	Hopper Collar		P2330	Aluminum Grill
				P2331	Fiberglass Grill

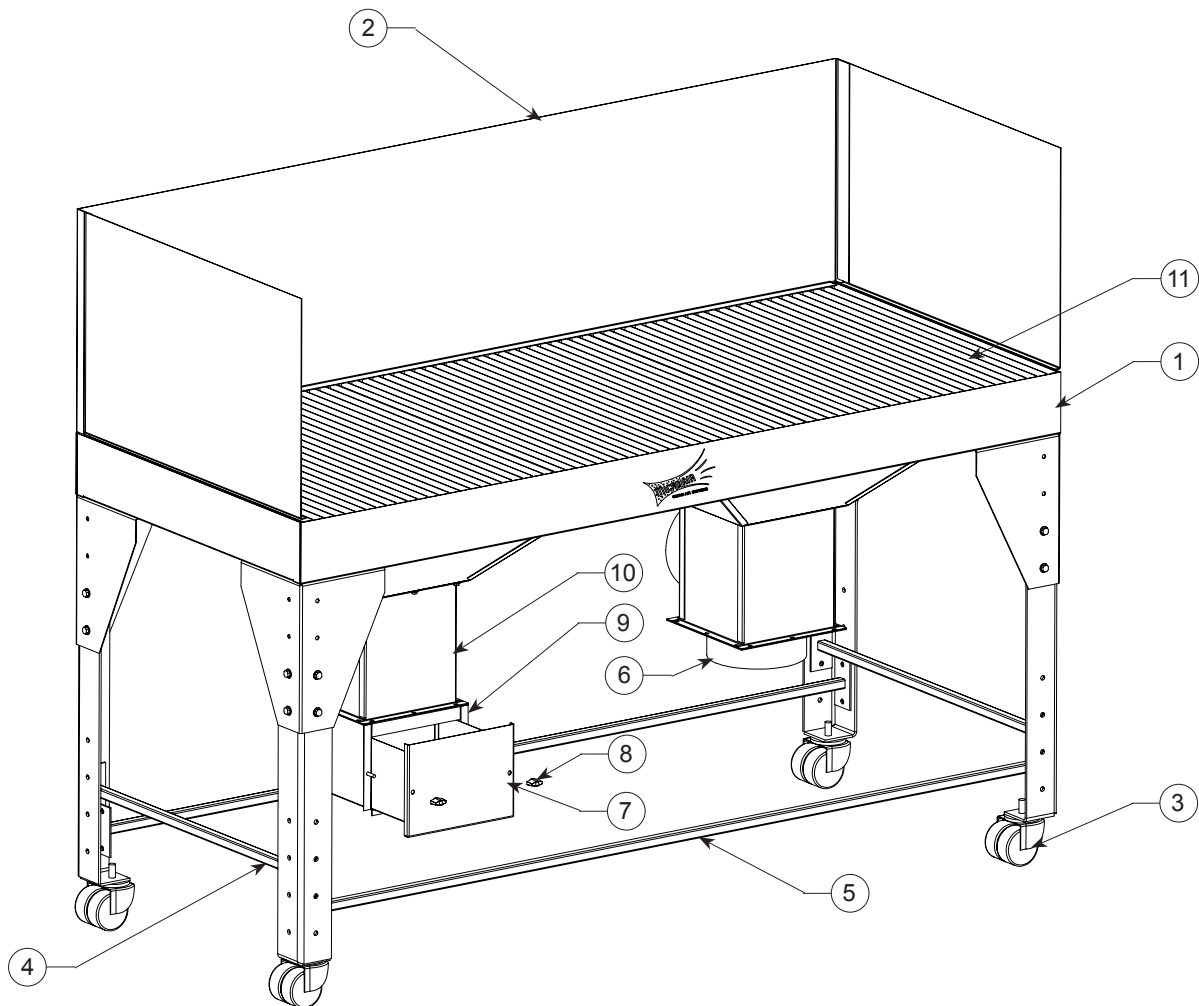

FIG. 7

