

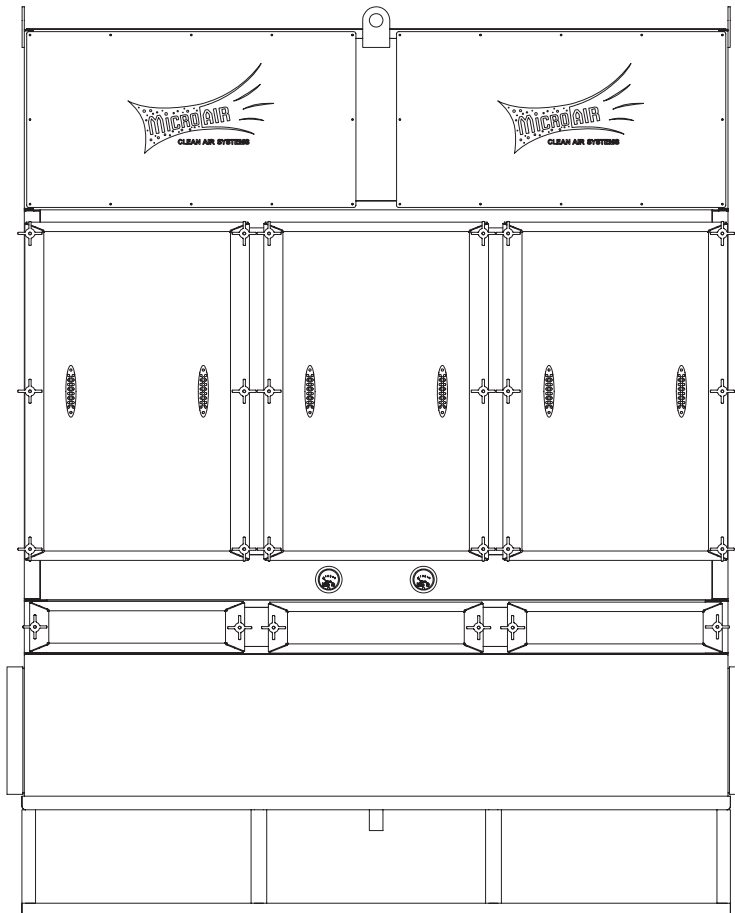

MISTMAX™

MODEL MM3600

Installation and Operation Manual



Important:

This manual contains specific cautionary statements relative to worker safety. Read this manual thoroughly and follow as directed. It is impossible to list all the hazards of oil mist control equipment. All persons involved with the equipment or systems should be instructed how to operate in a safe manner.

MODEL MM3600 SPECIFICATIONS

INPUT VOLTAGE:

208-230V / 460V 60Hz 3 Phase

MAXIMUM CURRENT:

Dual 7-1/2HP 208V: 19.6 Amps Each / 39.2 Amps Total
230V: 18.4 Amps Each / 36.8 Amps Total
460V: 9.2 Amps Each / 18.4 Amps Total

MOTOR:

Dual 7-1/2HP 3 Phase 3450 RPM TEFC

OVERALL DIMENSIONS:

Base Unit: 103" H x 78" W x 25" D (including stand)

FILTER AREA:

306 Sq. Feet

PACKAGE CONTENTS:

1 Ea. MM3600
1 Ea. Owners Manual
1 Ea. Motor Control Box
6 Ea. P7291 Cartridge Filter

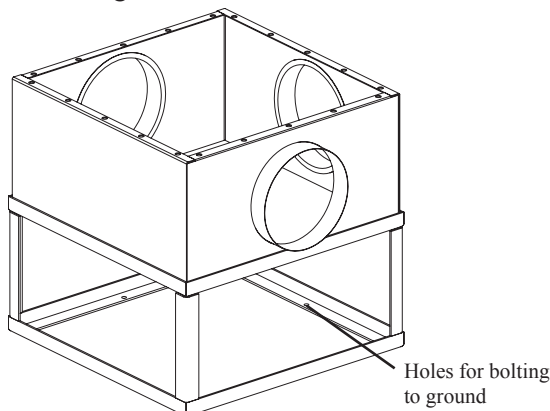

Fig. 1

INSPECTION:

The Micro Air oil mist unit is shipped on one skid. This skid should be inspected for any visible damage that may have occurred during shipment. Note any damage on the packing slip.

EQUIPMENT/TOOLS REQUIRED:

- Standard Wrenches
- Forklift
- Screwdriver
- Pipe Wrench

ASSEMBLY OF UNIT:

Determine the location where the air cleaner is to be installed. Be sure to allow sufficient room around the unit to service the filters, and allow for exhaust air. When selecting a location consider the floor surface. It needs to be smooth and level.

1. Un-crate the unit. Use caution not to damage the paint while dismantling the crate.
2. Remove any options ordered from the skid.
3. Using a forklift and lifting chains or straps, lift the air cleaner off the skid and stand it on its legs.
4. Carefully place the oil mist air cleaner into its location.
5. Bolt the air cleaner to the floor in its final location using the provided holes in the floor stand. (Fig 1).
6. Install the cartridge filters and lock into place by pulling forward on the lift levers.

⚠ CAUTION: The Weight of the unit is not evenly dispersed and the unit could tip over.

ELECTRICAL INSTALLATION:

⚠ All electrical work must be done by a qualified electrician according to local, state and national codes.

⚠ CAUTION: Installation can cause exposure to live components. Disconnect electrical power before proceeding with installation. Proper Lock Out / Tag Out procedures should be used.

1. Determine the location for the Motor Control Box.
2. Make electrical connections as shown in the wiring diagram to the wires protruding from the conduit on the side of the unit.
3. Check both blowers for proper rotation direction. If a blower rotates backwards, interchange two of the motor supply connections (L1 and L2) to the affected motor.
4. Check current draw of motors. Do not exceed specified amprage.

OIL DRAINAGE:

Note: Should captured oil be disposed of, make sure to follow local codes.

⚠ CAUTION: Any duct used to connect the mist collector to the machine should slope towards the machine in order to prevent oil build up in the duct work. If this is not possible a method of draining oil from the ductwork should be provided.

Provision for draining oil from the air cleaner is provided for by a 1" N.P.T. pipe coupling on the bottom of the unit. Drainage can be piped to a central collection system or collected in a bucket placed under the unit. In all cases a shut-off valve or drain trap is required to prevent air bypass through the drain opening. One of the drain systems shown in (Fig. 2) should be used. Drain connections and lines are not provided.

Note: If a shut off valve is installed in the drain system, the unit must be emptied regularly to prevent oil from overflowing into the intake duct.

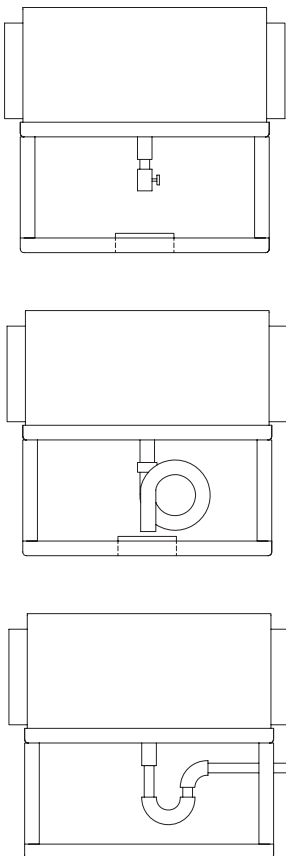

Fig. 2

OPERATION:

1. To start unit, turn the switch to the ON position. To stop the unit, turn the switch to the OFF position.

GENERAL MAINTENANCE:

1. No lubrication is required for the motor because it is a permanent pre-lube design. Excessive dirt / oil should be periodically removed.
2. Make sure oil is draining easily through drain pipe.

CHANGING FILTERS:

⚠ CAUTION: Always make sure that the unit is turned off before changing filters or servicing the unit.

1. The MM3600 is equipped with dual filter gauges (0-5" for pre-filter and 0-10" for main filters). The pre-filter should be removed, cleaned and inspected when the gauge labeled pre-filter reads 2" W.C. The main filters should be removed and replaced when the gauge labeled main filter reads between 6" W.C. and 8" W.C. (depending on desired airflow).
2. The pre-filters should be cleaned in a detergent solution to remove dirt and oil residue.
3. Rinse the pre-filters thoroughly with water, shake dry and replace in the unit.
4. Start the unit. The filter gauge should read below 2" for the pre-filters or below 6" for the main filters.

OPTIONAL HEPA AFTER FILTER:

1. Remove the bolts and washers from the exhaust grille.
2. Place Hepa filter and Hepa filter enclosure on top of the exhaust grille.
3. Align the holes of the Hepa filter enclosure with those on the blower cabinet.
4. Insert bolts and washers and tighten until secure.

MM3600

INPUT VOLTAGE (3 PH)

- 208-230 VAC.
- 460 VAC.
- OTHER: _____ VAC.

FREQUENCY

- 60 HZ.

MAXIMUM CURRENT

- _____ AMPS

CAUTION: DISCONNECT POWER TO UNIT PRIOR TO SERVICING OR INSTALLATION OF PARTS.

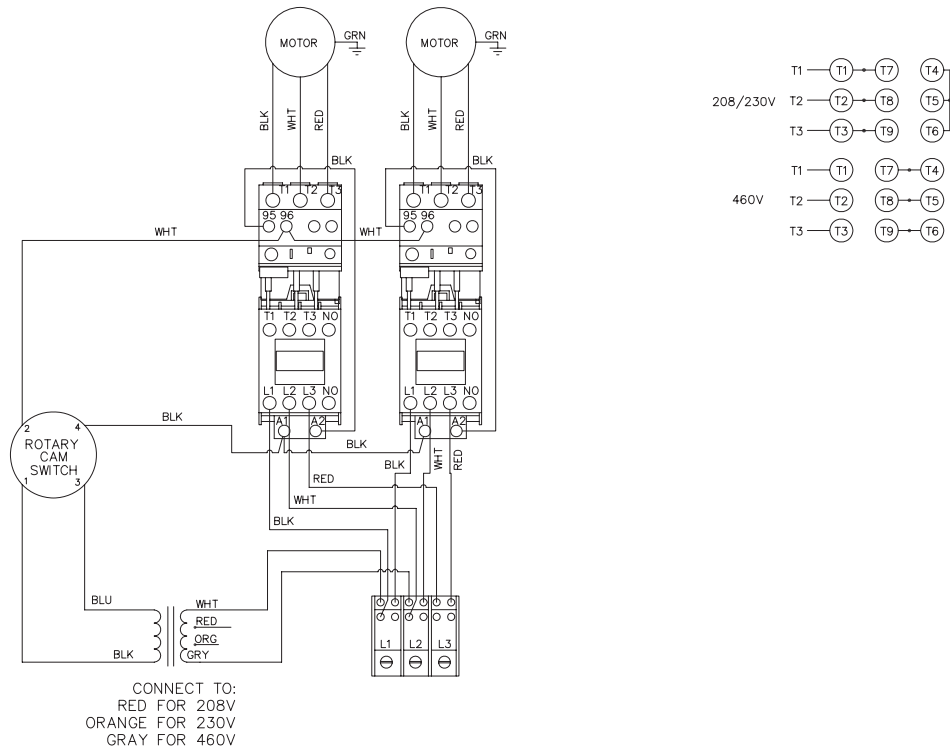

METAL-FAB INC, WICHITA KS.

P7323

208/230/460 Volt Wiring Diagram

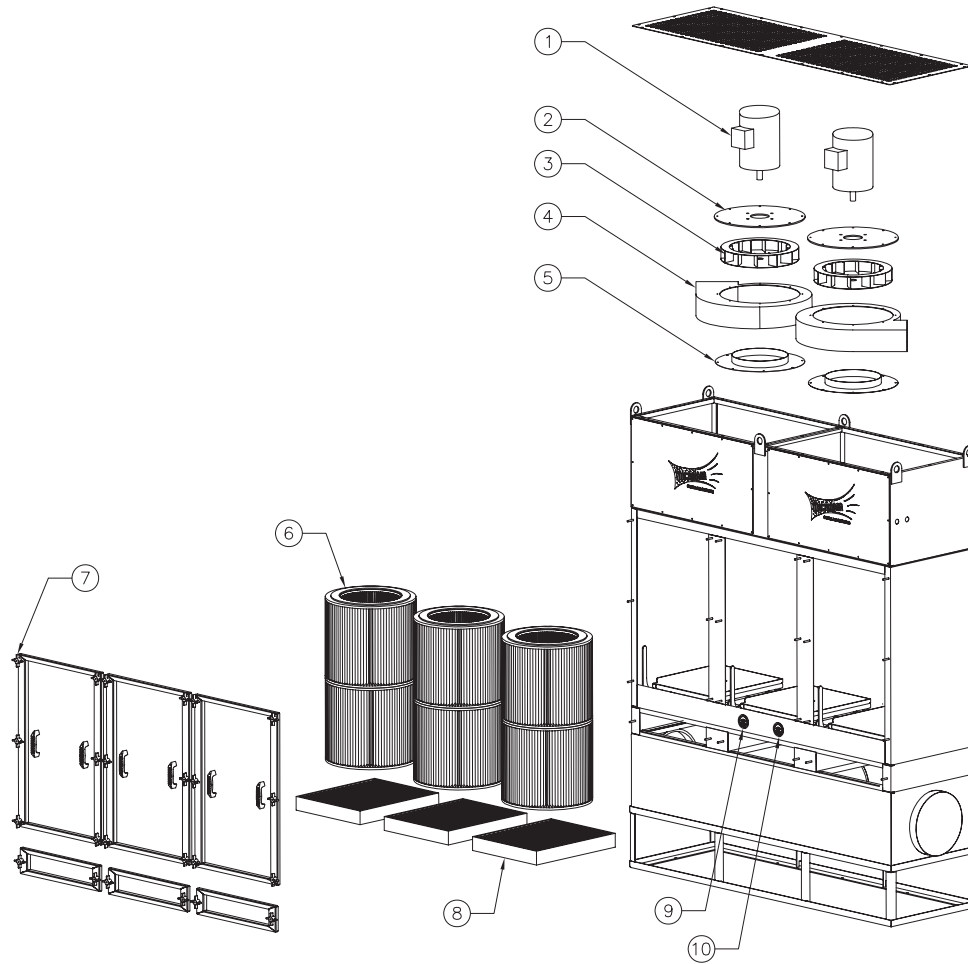

MM3600 PARTS LIST

ITEM	PART NO.	DESCRIPTION
①	P7326	7-1/2 HP Motor
②	38785-02	Motor Mounting Plate
③	P7325	Blower Wheel
④	P7316	Blower Housing
⑤	P7317	Blower Inlet Plate
⑥	P7291	Cartridge Filter
⑦	P3649	4-Prong Knob
⑧	P7292/P1828 & P7309	Mist-X Pre-Filter / Baffle & Mesh Pre-Filter
⑨	P2221	0-5" W.C. Mini-Helic Gauge
⑩	P7297	0-10" W.C. Mini-Helic Gauge