

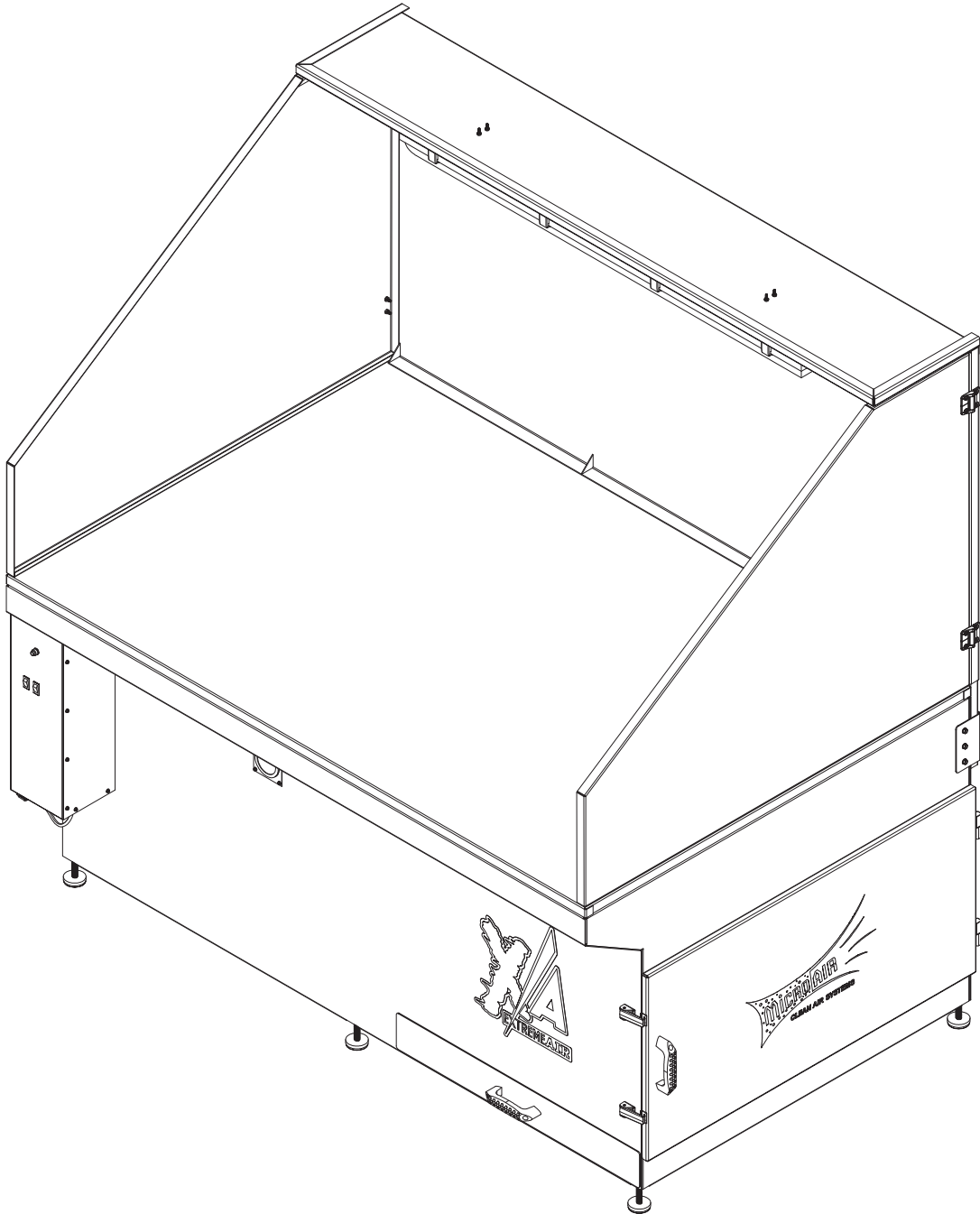

XA46 Max

Installation and Operation Manual



Important:

This manual contains specific cautionary statements relative to worker safety. Read this manual thoroughly and follow as directed. It is impossible to list all the hazards of dust control equipment. All persons involved with the equipment or systems should be instructed how to operate in a safe manner.

WARNINGS:

⚠ All electrical work must be done by a qualified electrician according to local, state and national codes.

⚠ CAUTION: Installation can cause exposure to live components. Disconnect electrical power before proceeding with installation. Proper Lock Out / Tag Out procedures should be used.

Improper installation or operation of this equipment can cause damage to equipment and / or injury to personnel. The installation/operation manual must be read and followed in its entirety.

SPECIFICATIONS XA46:

Input Voltage:	230/460 VAC 3-Phase
Motor:	5 HP TEFC
Max Current:	12.6/6.3 Amps
Filter Area:	300-500 square feet (media dependent)
Load Capacity:	1,800 pounds
Air Flow:	6,000 CFM
Capture Velocity:	250 FPM average @ 1" above work surface.
Noise level:	79 dBA at operator 74 dBA at operator with silencer
Overall Dimensions:	Base table: 36H x 75W x 49D With shields: 73H x 75W x 49D

COMPRESSED AIR REQUIREMENTS:

3/4" Air line with clean, dry compressed air regulated to 80-90 psi max is required for proper operation of the Roto-Pulse filter cleaning system. It is recommended that a pressure regulator and coalescing filter be installed between the compressed air source and the inlet to the down draft table.

EQUIPMENT/TOOLS REQUIRED:

- Standard wrenches
- Forklift
- Pipe wrench
- Cordless drill

INSTALLATION:

1. Inspect the Unit for any visible damage that may have occurred during shipment. Note any damage on the packing slip.
2. Uncrate the unit. Use caution not to damage the paint while dismantling the crate.
3. Remove any options ordered from the skid.
4. Using a forklift, lift the unit off of the skid. Carefully place the downdraft table into its location.
5. Connect compressed air supply to the 3/4" NPT nipple on the unit.
6. Connect the wire whip to the appropriate plug based on unit and voltage ordered. Plug into properly sized electrical outlet.
7. Mount any optional accessories per instructions if ordered.

OPERATION:

- To start the unit, toggle the switch located on the front of the unit to the ON position. To stop the unit, toggle the switch to the OFF position.
- If equipped: To turn the light on toggle the switch located on the front of the unit to the ON position. To turn the light off, toggle the switch to the OFF position.
- To clean filters depress and hold down the pulse push-button for 2 seconds at least once per hour, and once after shutdown.
- Units equipped with auto-pulse do not require manual activation of the pulse system while the unit is running. The filters will clean automatically for 2 seconds, every 45 seconds that the unit is running. It is recommended that at least one manual pulse is completed after the unit is turned off.

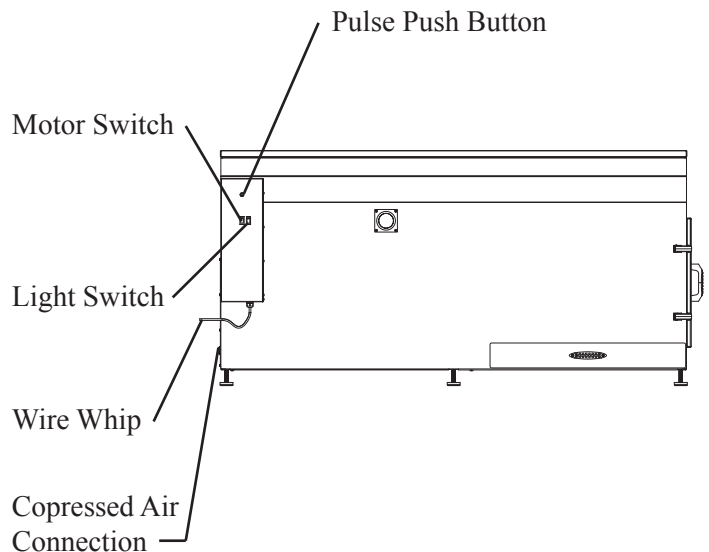
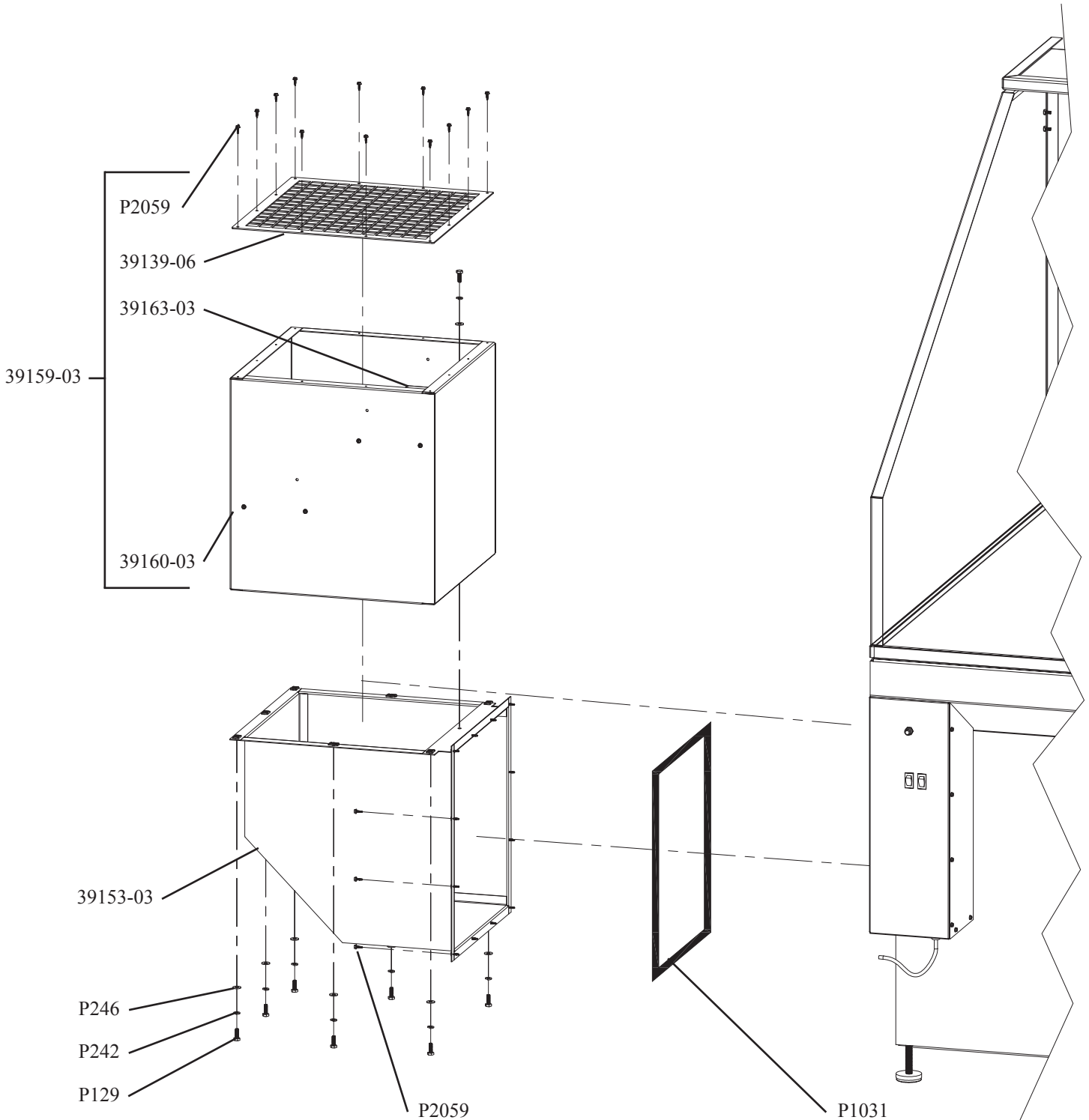

FIG 1.

OPTIONAL SILENCER ASSEMBLY INSTRUCTIONS

1. Remove all items from packaging.
2. Apply foam (P1031) to the transition as shown.
3. Using supplied sheet metal screws (P2059) align and attach transition to pre-drilled holes in the unit.
4. Using supplied bolts (P129) and associated hardware (P242, P246) bolt the silencer filter to the transition.



XA46 MAX WIRING DIAGRAM

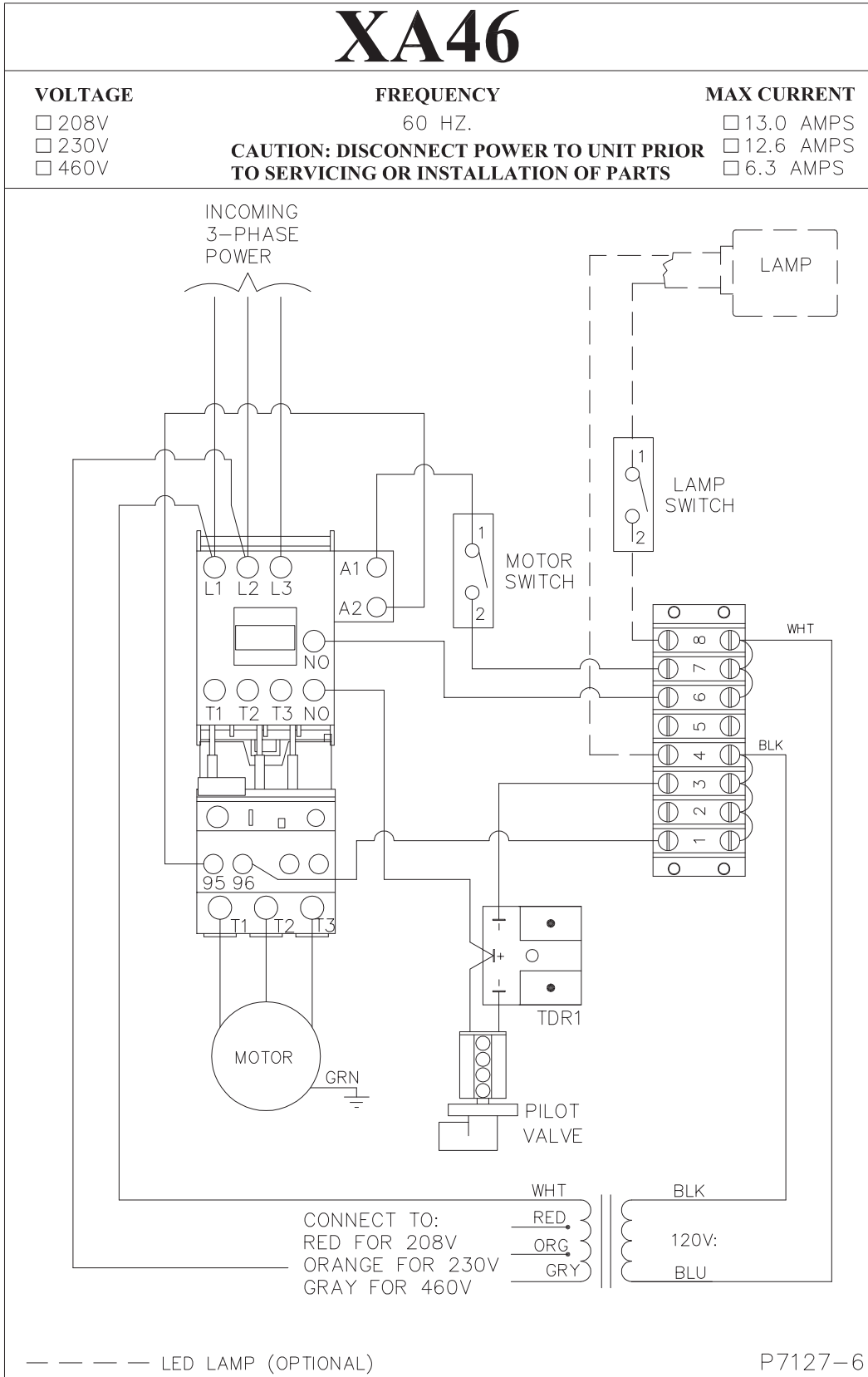

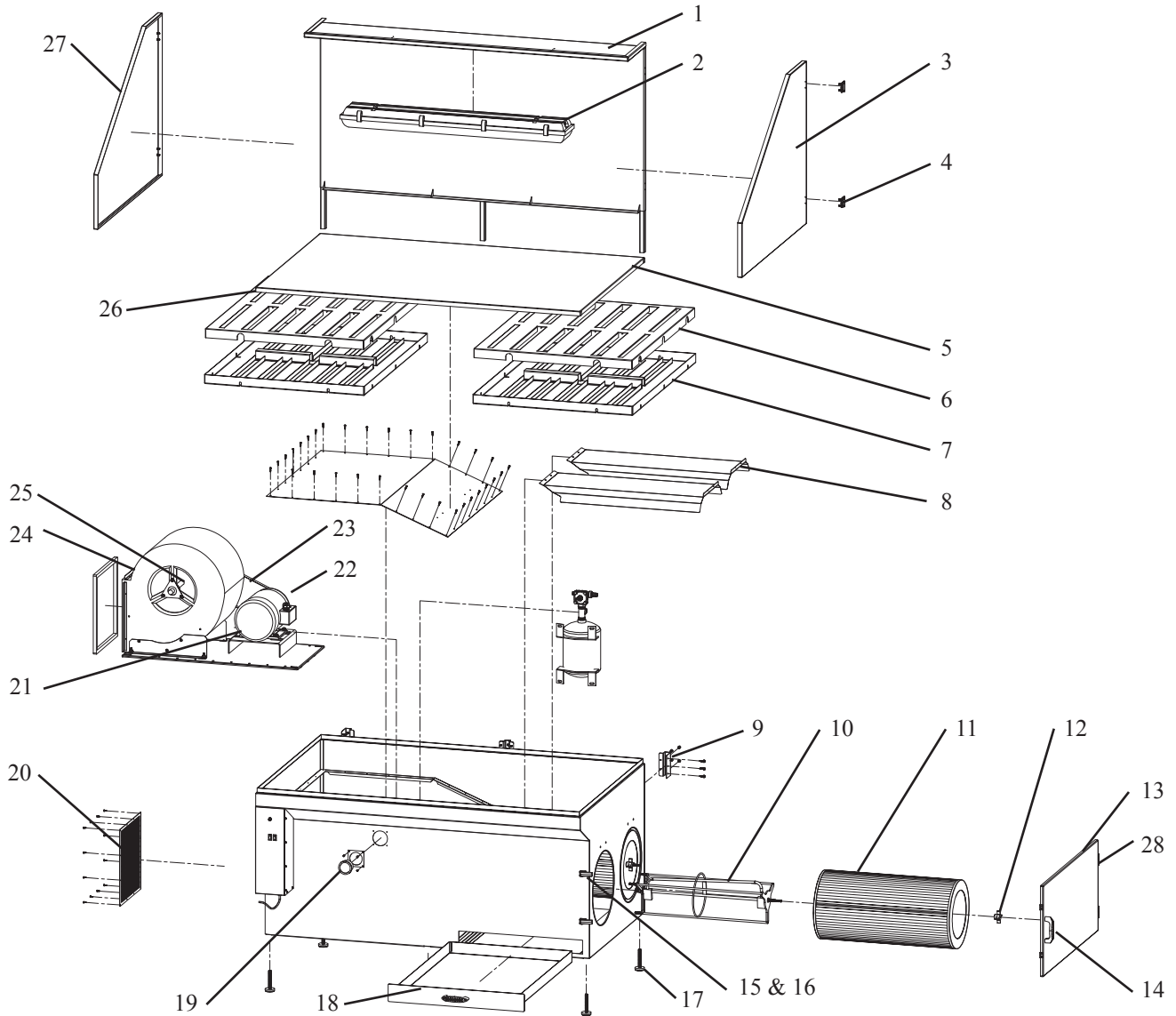

Item	Part No.	Description
1.	39130-04	Back & Top Shield
2.	P7171	4' Dust Proof LED Light Fixture
3.	39133-06	Side Shield - Right
4.	P7105	Hinge
5.	39108-04	Perforated Table Top
	P7134	Rubber Work Mat
6.	39127-04	Top Baffle
7.	39124-03	Bottom Baffle
8.	39115-03	Filter Cover
9.	39110-01	Shield Bracket
	39110-02	Center Shield Bracket
10.	36720-11	Roto-Pulse Assembly
11.	P7400RM	80/20 Cartridge Filter
	P7405RM	100% Spunbond Cartridge Filter
	P7415NM	Nano-Max Cartridge Filter
	P7406RM	PTFE Cartridge Filter
12.	P3649	4-Prong Knob
13.	39135-02	Access Door

Item	Part No.	Description
14.	P7108	Handle
15.	P7106	Under Center Latch
16.	P7107	Latch Catch
17.	P7102	Leveling Leg
	P2334	3" Swivel Caster
18.	39120-05	Dust Drawer Assembly
19.	P2221	0-5" Mini-Helic gauge
20.	39139-05	Exhaust Grille
21.	P3253	5HP TEFC Motor
22.	P3267	Motor Pulley
23.	P3452	Drive Belt
24.	P3260	Blower
25.	P3986	Blower Pulley
26.	P1719	Edge Guard
27.	39133-05	Side Shield - Left
28.	P7109	Lift Off Hinge
N/S	P2075	Diaphragm Valve

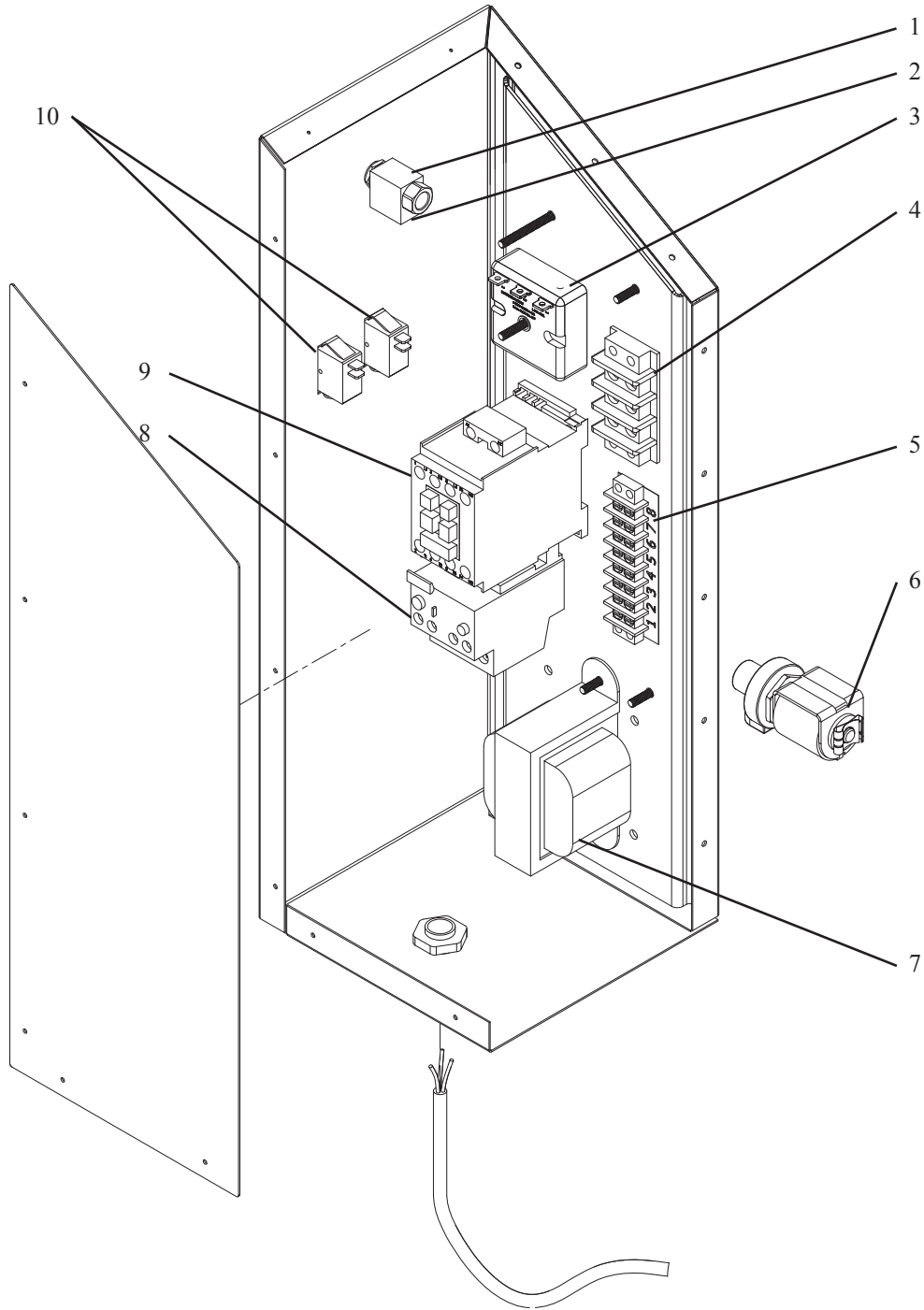

Item	Part No.	Description	Item	Part No.	Description
1.	P2766	Push Button Air Valve	6.	P3118	Pilot Valve
2.	P3735	1/4" Elbow Preslock Fitting	7.	P1754	Transformer
3.	P2922	Auto-Pulse Timer	8.	P3915	Overload
4.	P445	3 Conn. Terminal Block	9.	P3910	Motor Contactor
5.	P3246	8 Conn. Terminal Block	8.	P2219	On / Off Switch